

Cambridge International AS & A Level

PHYSICS (9702) P1

TOPIC WISE QUESTIONS & ANSWERS | COMPLETE SYLLABUS



Chapter 5

Forces, density and pressure

5.1 Types of force

364. 9702_m20_qp_12 Q: 11

A particle is in a uniform field. The particle experiences a force in the opposite direction to the field.

In which type of field is the particle, and on which property of the particle is the field acting?

	type of field	property of particle on which the field acts
A	electric	charge
B	electric	current
C	gravitational	mass
D	gravitational	weight

365. 9702_s20_qp_12 Q: 10

The diagrams show a negative electric charge situated in a uniform electric field and a mass situated in a uniform gravitational field.

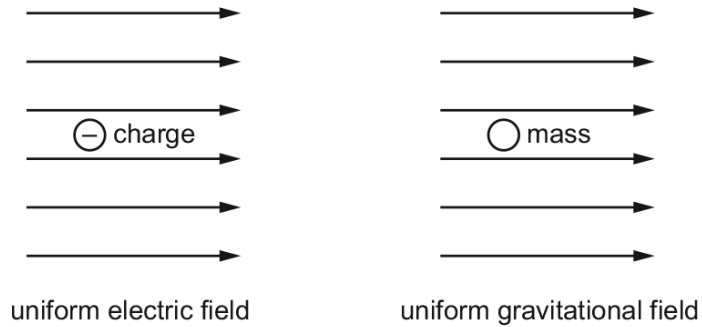

Which row shows the directions of the forces acting on the charge and on the mass?

	charge	mass
A		
B		
C		
D		

366. 9702_m19_qp_12 Q: 11

A ball falls through a liquid at a constant speed. It is acted upon by three forces: an upthrust, a drag-force and its weight.

Which statement is correct?

- A The drag-force increases with increasing depth.
- B The drag-force is equal to the sum of the upthrust and weight.
- C The upthrust is constant with increasing depth.
- D The weight is greater than the sum of the drag-force and the upthrust.

367. 9702_s19_qp_12 Q: 12

A submarine descends vertically at constant velocity. The three forces acting on the submarine are viscous drag, upthrust and weight.

Which relationship between their magnitudes is correct?

- A weight < drag
- B weight = drag
- C weight < upthrust
- D weight > upthrust

368. 9702_w19_qp_12 Q: 10

A positively charged oil droplet falls in air in a uniform electric field that is vertically upwards. The droplet has a constant terminal speed v_0 and the electric field strength is E .

The magnitude of the force due to air resistance acting on the droplet is proportional to the speed of the droplet.

Which graph shows the variation with E of v_0 ?

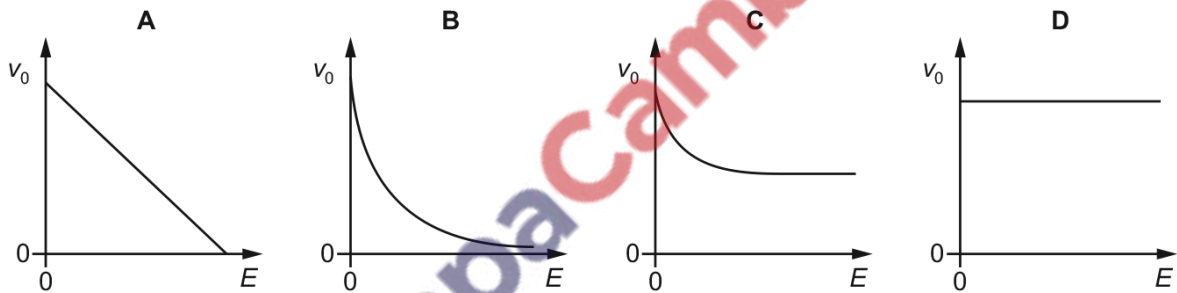

369. 9702_m18_qp_12 Q: 12

A charged oil drop is held stationary between two charged parallel plates.

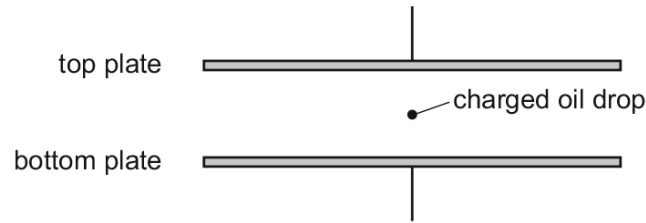

Which forces act on the oil drop?

- A both electric and gravitational
- B electric only
- C gravitational only
- D neither electric nor gravitational

370. 9702_s18_qp_12 Q: 11

An astronaut throws a stone horizontally near to the surface of the Moon, where there is no atmosphere.

Which row describes the horizontal and vertical forces acting on the stone after release?

	horizontal force	vertical force
A	non-zero and constant	constant
B	non-zero and constant	decreasing
C	zero	constant
D	zero	decreasing

371. 9702_w18_qp_11 Q: 10

A charged particle is placed in a uniform field of force. The direction of the force on the particle is opposite to the direction of the field.

What is the field and what is the charge on the particle?

	field	charge on particle
A	electric	negative
B	electric	positive
C	gravitational	negative
D	gravitational	positive

372. 9702_w18_qp_12 Q: 11

A positively-charged particle of negligible mass, moving at constant velocity v in a vacuum, enters a uniform electric field between two parallel plates, as shown.

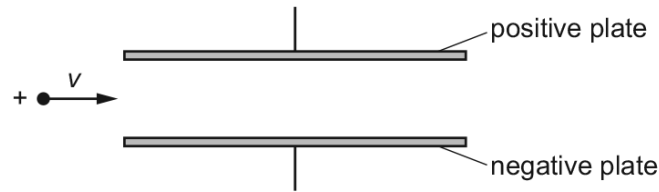

A short time later, the particle is at the position shown.

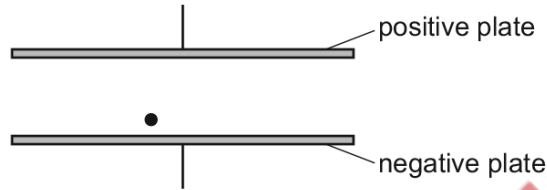

Which diagram represents the force or forces acting on the particle?

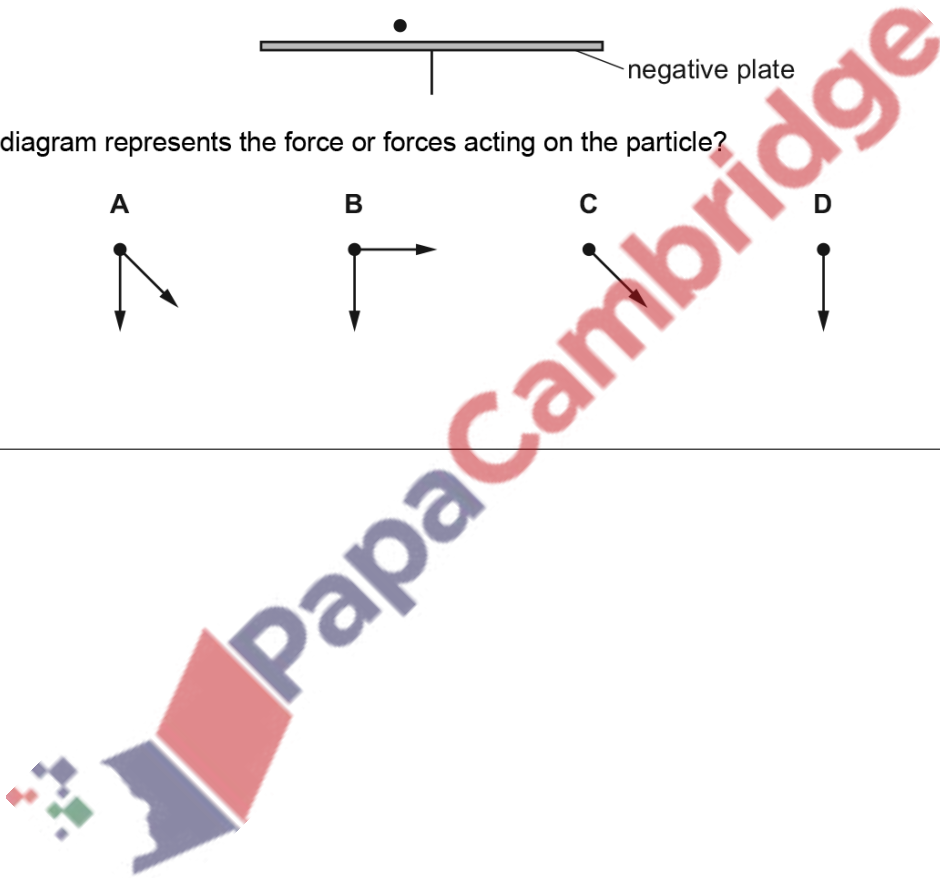
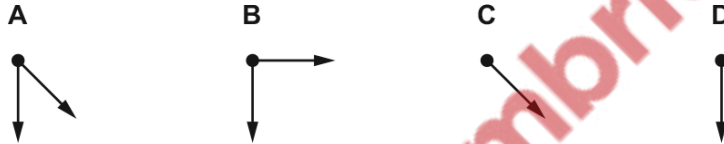

373. 9702_w18_qp_13 Q: 11

A rigid, hollow sphere is immersed deep in water and released from rest. It experiences an upthrust which propels it towards the surface of the water.

Which graph best shows the variation with time t of its upward velocity v ?

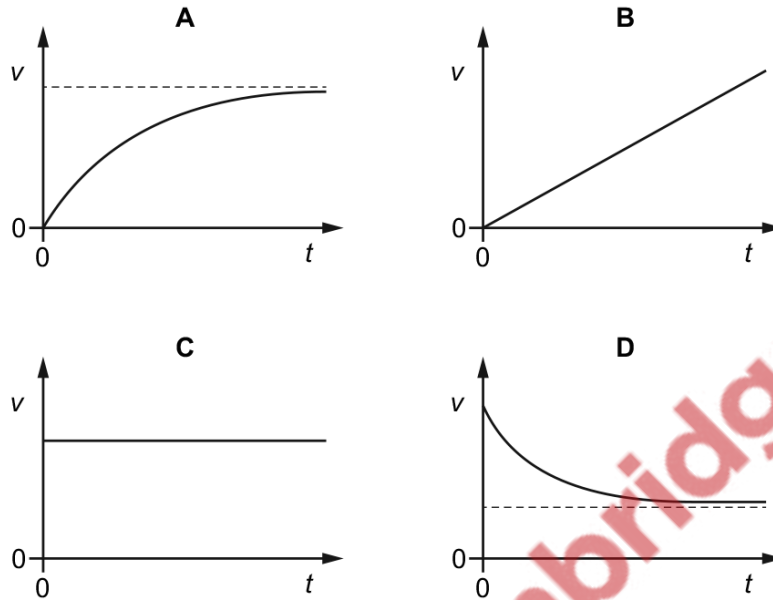

374. 9702_m17_qp_12 Q: 13

The vertical forces that the ground exerts on a stationary van are shown.

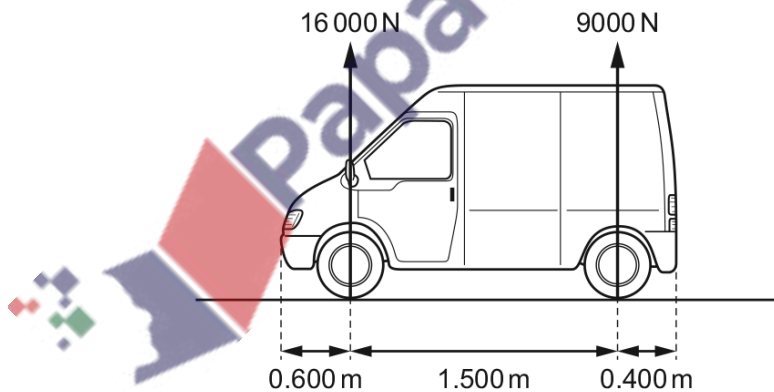

The van is 2.50 m long with the wheels at a distance of 0.600 m from the front of the van and 0.400 m from the rear of the van.

What is the horizontal distance of the van's centre of gravity from the front of the van?

- A** 0.540 m **B** 0.960 m **C** 1.14 m **D** 1.36 m

375. 9702_m17_qp_12 Q: 15

Which force is caused only by a pressure difference?

- A friction
- B upthrust
- C viscous force
- D weight

376. 9702_s17_qp_11 Q: 11

A particle with mass and charge is moving from left to right in a uniform gravitational field and a uniform electric field. The gravitational field is downwards. The gravitational force and the electric force on this particle act in opposite directions.

What could be the sign of the charge on the particle and the direction of the electric field?

	sign of charge	direction of electric field
A	negative	down
B	negative	up
C	positive	left
D	positive	right

377. 9702_s17_qp_12 Q: 10

A metal cylinder is suspended vertically in equilibrium by a cord. The diagram shows the cylinder in four different positions P, Q, R and S.

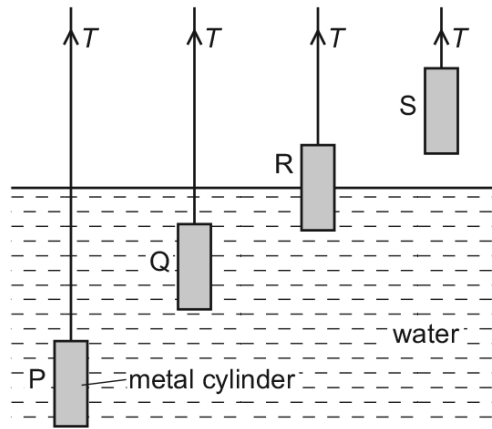

Which statement explains the variation of the tension T in the cord?

- A At P and at Q, the tension T in the cord is the same because the difference in pressure between the top and bottom of the cylinder is the same.
- B At Q, the tension T in the cord is less than at P because, at smaller depth, liquid pressure is smaller.
- C At R, the tension T in the cord is less than at P because atmospheric pressure is less than water pressure.
- D At S, the tension T in the cord is greater than at P because atmospheric pressure at S exerts no force on the top or bottom of the cylinder.



378. 9702_s17_qp_13 Q: 12

An air bubble is rising through a liquid at a constant speed. The forces on it are the upthrust U , the viscous drag D and its weight W .

Which diagram shows the directions and relative sizes of the forces?

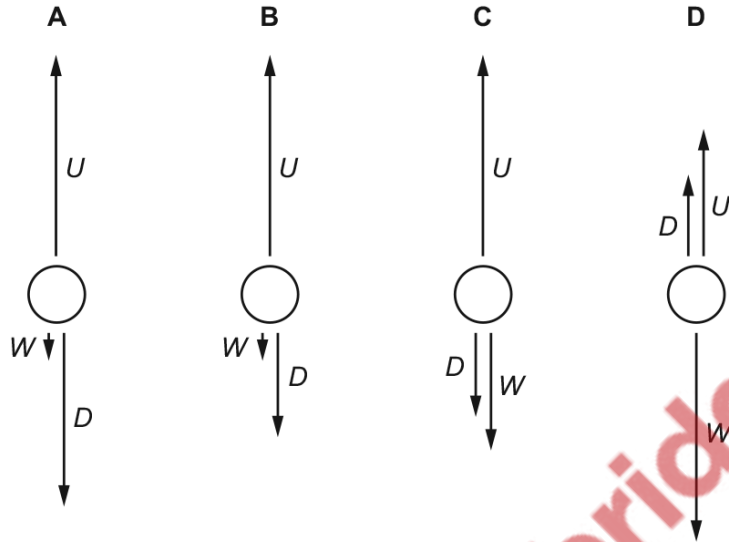

379. 9702_w17_qp_11 Q: 8

The three forces acting on a hot-air balloon that is moving vertically are its weight, the force due to air resistance and the upthrust force.

The hot-air balloon descends vertically at constant speed. The force of air resistance on the balloon is F .

Which weight of material must be released from the balloon so that it ascends vertically at the same constant speed?

- A** F **B** $2F$ **C** $3F$ **D** $4F$

380. 9702_w17_qp_11 Q: 12

A block is submerged vertically in a liquid. The four diagrams show, to scale, the forces exerted by the liquid on the block.

Which diagram correctly shows a possible situation as viewed from the side?

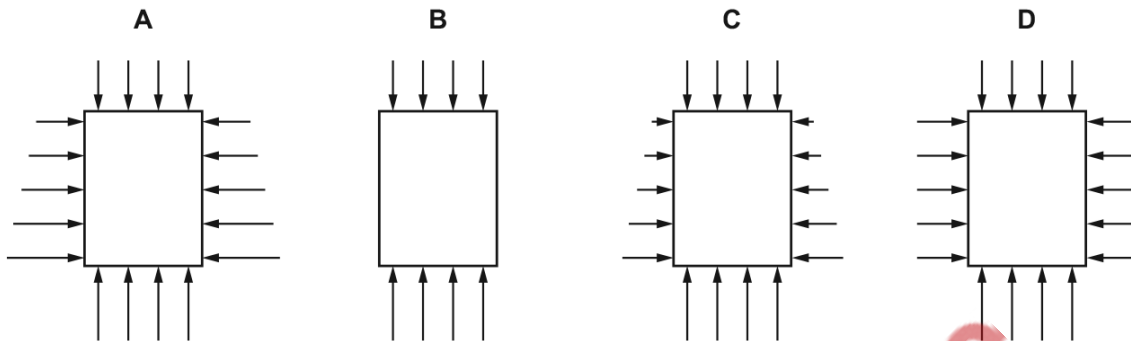

381. 9702_w17_qp_12 Q: 11

The diagram shows a block of copper suspended in water.

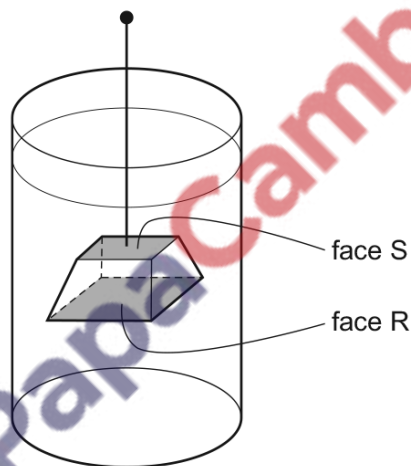

The block experiences an upthrust from the water.

Which statement is the basis of an explanation for this upthrust?

- A Copper is more dense than water.
- B The area of face R is greater than the area of face S.
- C The density of water increases with depth.
- D The pressure of water increases with depth.

382. 9702_w17_qp_13 Q: 11

A stone is projected horizontally in a vacuum and moves along the path shown.

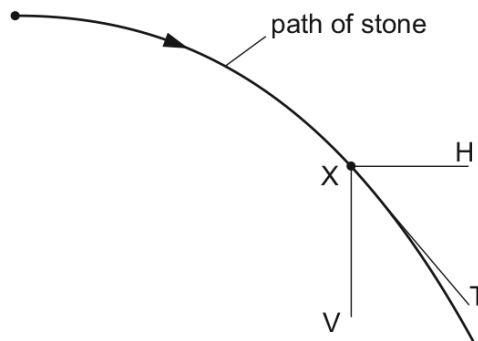

X is a point on this path. XV and XH are vertical and horizontal lines respectively through X. XT is the tangent to the path at X.

Along which directions do forces act on the stone at X?

- A** XV and XH **B** XV only **C** XH only **D** XT only

383. 9702_s16_qp_13 Q: 13

What is the centre of gravity of an object?

- A** the geometrical centre of the object
B the point at which the weight of the object may be considered to act
C the point on the object about which there is a zero net torque
D the point where gravity acts on the object

384. 9702_w16_qp_12 Q: 14

Which diagram best shows the forces acting on a ball falling at a constant velocity through a liquid?

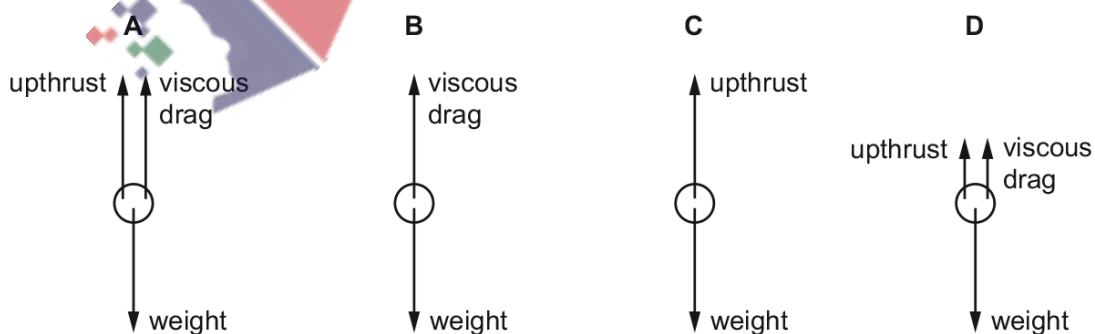

385. 9702_s15_qp_12 Q: 12

An astronaut throws a stone with a horizontal velocity near to the Moon's surface.

Which row describes the horizontal and vertical forces acting on the stone after release?

	horizontal force	vertical force
A	constant	constant
B	constant	decreasing
C	zero	constant
D	zero	decreasing

5.2 Turning effects of forces

386. 9702_m20_qp_12 Q: 12

A uniform rod of weight 20 N and length 2.0 m is acted upon by two vertical forces, as shown.



What are the resultant force acting on the rod and the resultant moment about the centre of gravity of the rod?

	resultant force /N	resultant moment /Nm
A	0	10
B	0	20
C	20	10
D	20	20

387. 9702_s20_qp_11 Q: 12

Which statement best describes a couple?

- A** a pair of forces of equal magnitude acting in opposite directions which produce rotational motion but not translational motion
- B** a pair of forces of equal magnitude acting in opposite directions which produce translational motion but not rotational motion
- C** a pair of forces of equal magnitude acting in the same direction which produce rotational motion but not translational motion
- D** a pair of forces of equal magnitude acting in the same direction which produce translational motion but not rotational motion

388. 9702_s20_qp_11 Q: 13

A uniform rod XY of weight 10.0 N is freely hinged to a wall at X. It is held horizontal by a force F acting from Y at an angle of 30° to the horizontal, as shown.

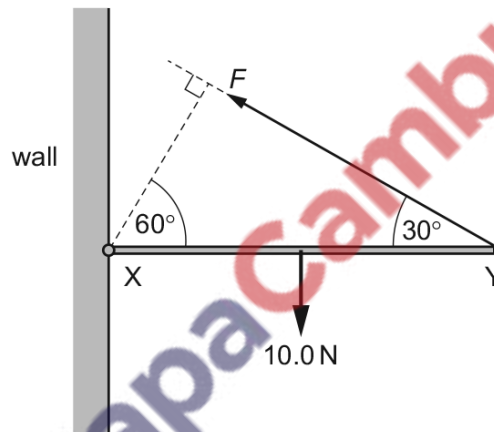

What is the value of F ?

- A** 5.0 N
- B** 8.7 N
- C** 10.0 N
- D** 20.0 N

389. 9702_s20_qp_12 Q: 11

A bicycle pedal is connected to a pivot by a metal bar, as shown.

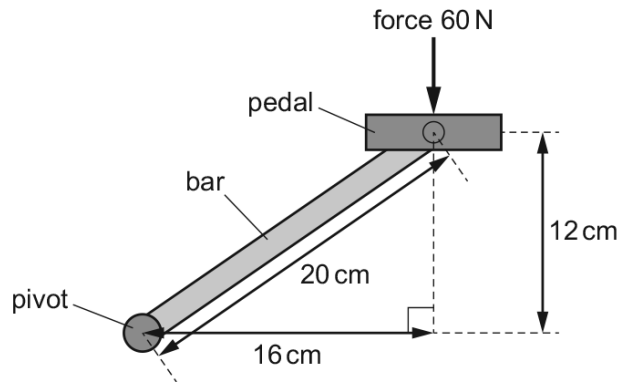

The force on the pedal is 60 N downwards.

What is the moment of this force about the pivot?

- A 7.2 Nm B 9.6 Nm C 12 Nm D 1200 Nm

390. 9702_s20_qp_13 Q: 12

Two forces, each of magnitude F , act along the edges of a rectangular metal plate, as shown.

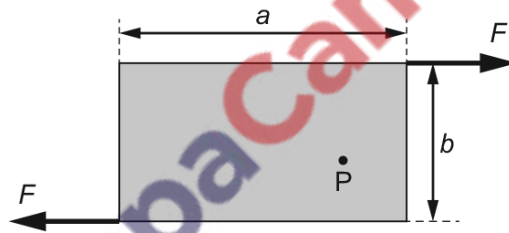

The plate has length a and width b .

What is the torque about point P ?

- A Fa B Fb C $2Fa$ D $2Fb$

391. 9702_m19_qp_12 Q: 12

A fairground ride consists of four carriages connected to a central vertical pole, as shown in the following view from above.

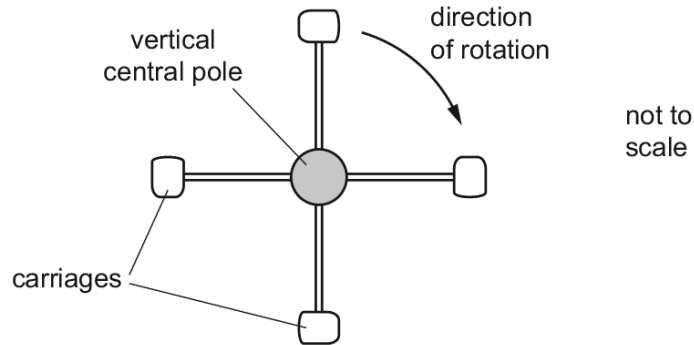

A motor rotates the central pole about its axis. This results in the four carriages each moving along a circular path.

The distance from the middle of each carriage to the centre of the pole is 3.20 m. When they are moving, each carriage experiences an air resistance force of 85.0 N. Assume that there are no other significant resistive forces.

Which torque does the motor need to apply to the pole to keep the system rotating at constant maximum speed?

- A** 5.44 Nm **B** 272 Nm **C** 544 Nm **D** 1090 Nm

392. 9702_s19_qp_11 Q: 13

A couple is applied to a tap as shown.

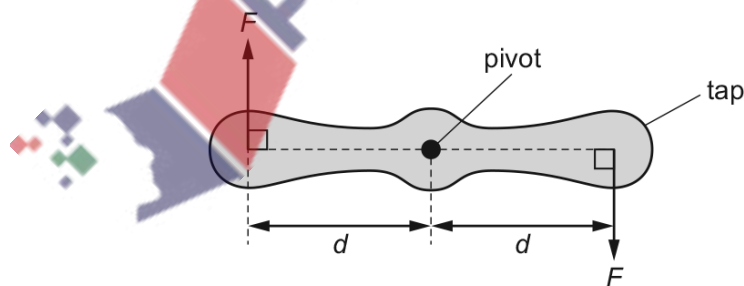

What is the torque of the couple?

- A** $\frac{Fd}{2}$ **B** Fd **C** $2Fd$ **D** $4Fd$

393. 9702_s19_qp_13 Q: 13

What is the torque of the couple shown?

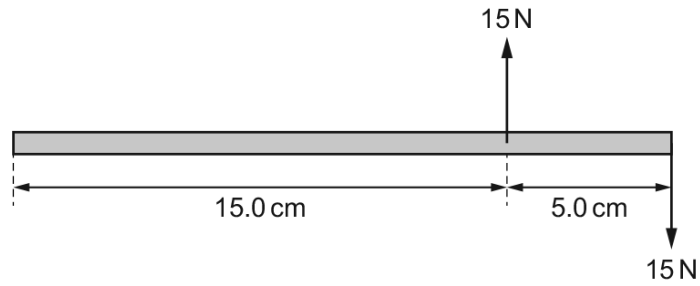

- A 0.75 Nm B 1.50 Nm C 3.00 Nm D 5.25 Nm

394. 9702_w19_qp_11 Q: 12

Which diagram shows a couple?

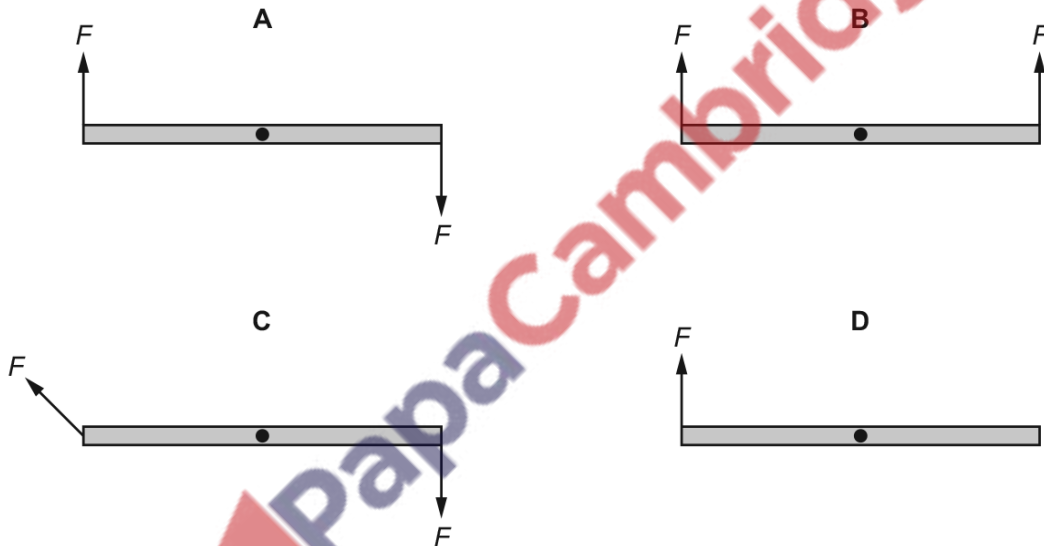

395. 9702_w19_qp_13 Q: 11

The diagram shows two pairs X and Y of parallel forces.

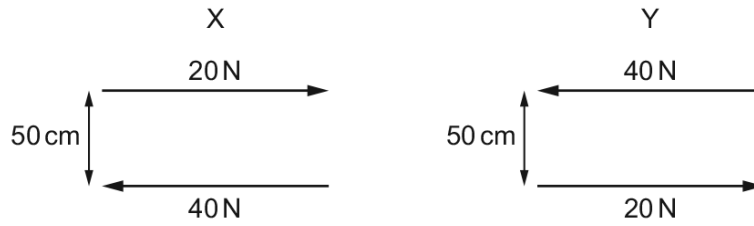

Which statement is correct?

- A X is equivalent to a clockwise torque of 10 N m and a force of 20 N to the left.
- B X is equivalent to a clockwise torque of 20 N m only.
- C Y is equivalent to an anticlockwise torque of 30 N m and a force of 20 N to the left.
- D Y is equivalent to an anticlockwise torque of 30 N m only.

396. 9702_m18_qp_12 Q: 11

The diagram shows four forces applied to a circular object.

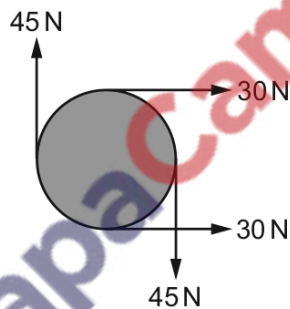

Which row describes the resultant force and resultant torque on the object?

	resultant force	resultant torque
A	non-zero	non-zero
B	non-zero	zero
C	zero	non-zero
D	zero	zero

397. 9702_s18_qp_11 Q: 10

A horizontal metal bar PQ of length 50.0 cm is hinged at end P. The diagram shows the metal bar viewed from above.

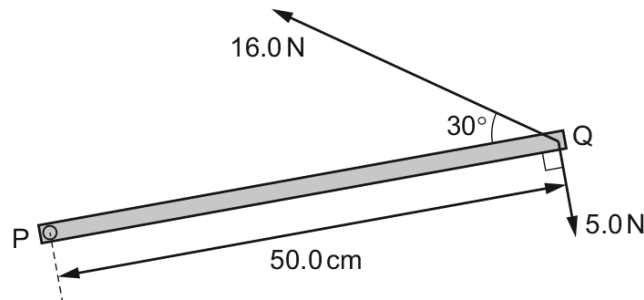

Two forces of 16.0 N and 5.0 N are in the horizontal plane and act on end Q as shown in the diagram.

What is the total moment about P due to the two forces?

- A 1.5 Nm B 4.4 Nm C 6.5 Nm D 9.4 Nm

398. 9702_s18_qp_11 Q: 12

Two parallel forces, each of magnitude F , act on a rod of length $5d$.

Which diagram shows the positions of the two forces that will produce the largest torque on the rod?

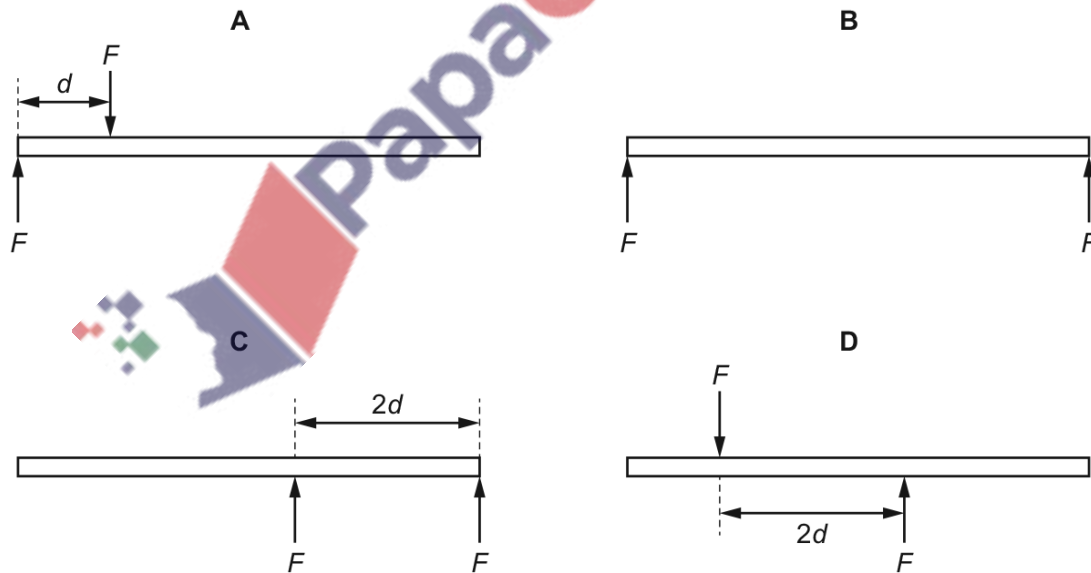

399. 9702_s18_qp_12 Q: 13

A uniform diving-board is held by two fixed rods at points P and Q. A person stands at end R of the diving-board, as shown.

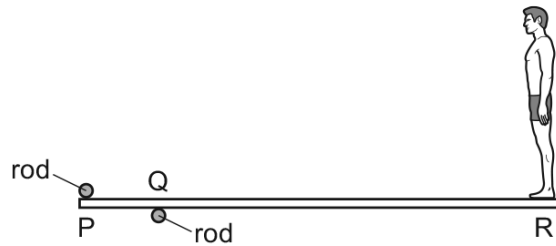

The forces exerted by the rods on the board are vertical. The board remains in equilibrium as the person slowly moves towards point Q from end R.

Which row describes the changes to the forces exerted by the rods on the board?

	force at P	force at Q
A	decreases	decreases
B	decreases	increases
C	increases	decreases
D	increases	increases

400. 9702_s18_qp_12 Q: 14

Two forces, each of magnitude F , act in opposite directions on a rod.

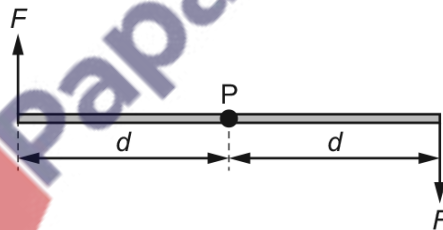

Each force acts on the rod at a distance d from the pivot P.

What is the torque of this couple about P?

- A** 0 **B** $F \times d$ **C** $2F \times d$ **D** $2F \times 2d$

401. 9702_s18_qp_13 Q: 12

Which diagram shows a couple formed by two forces, each of magnitude F , acting on a rod?

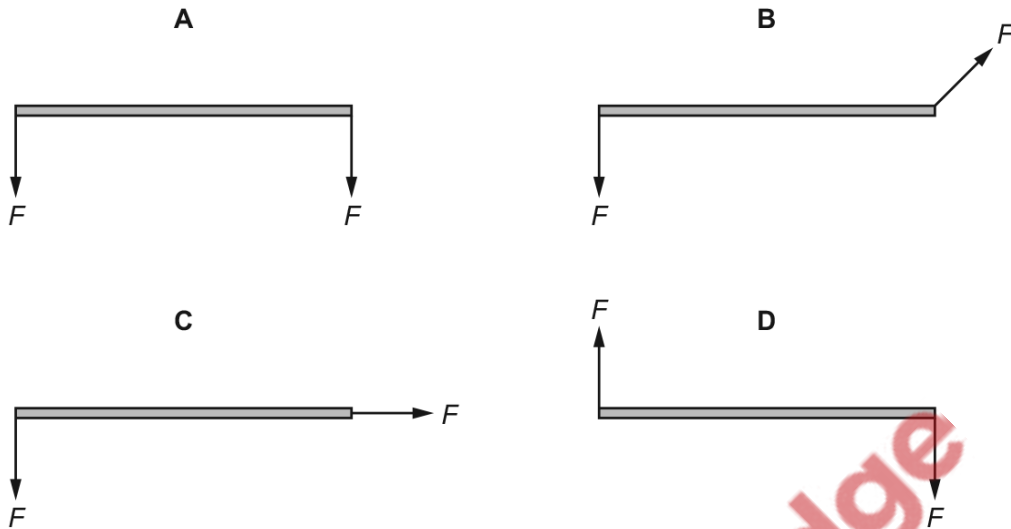

402. 9702_w18_qp_13 Q: 12

A flat metal disc has radius R .

Forces of magnitude F are applied tangentially at the edge of the disc. The forces are in the plane of the disc.

Which arrangement of forces produces only a torque of magnitude $2FR$?

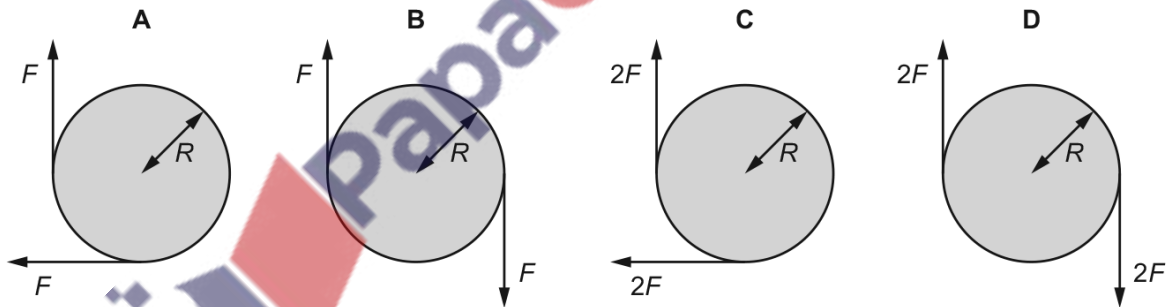

403. 9702_m17_qp_12 Q: 12

A uniform metre rule of weight 2.0 N is pivoted at the 60 cm mark. A 4.0 N load is suspended from one end, causing the rule to rotate about the pivot.

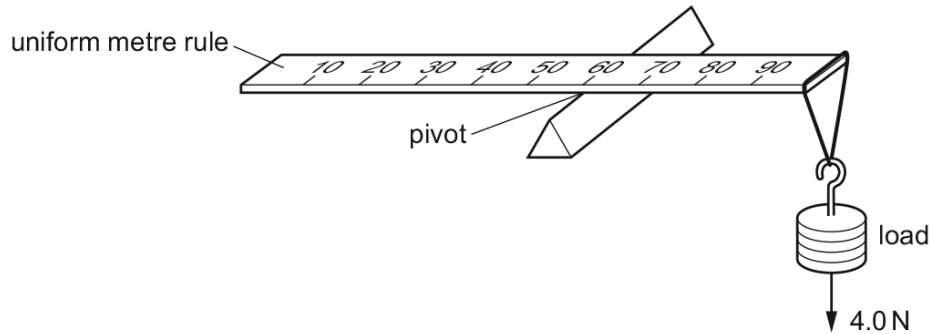

At the instant when the rule is horizontal, what is the resultant moment about the pivot?

- A** 0.0 N m **B** 1.4 N m **C** 1.6 N m **D** 1.8 N m

404. 9702_s17_qp_11 Q: 12

A sphere is acted upon by various forces, all of the same magnitude.

Which system of forces provides a resultant torque but zero resultant force on the sphere?

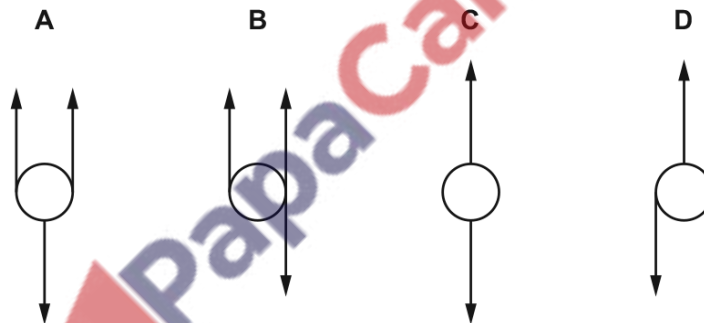

405. 9702_s17_qp_12 Q: 11

In a machine, many couples act on a rotating object as shown.

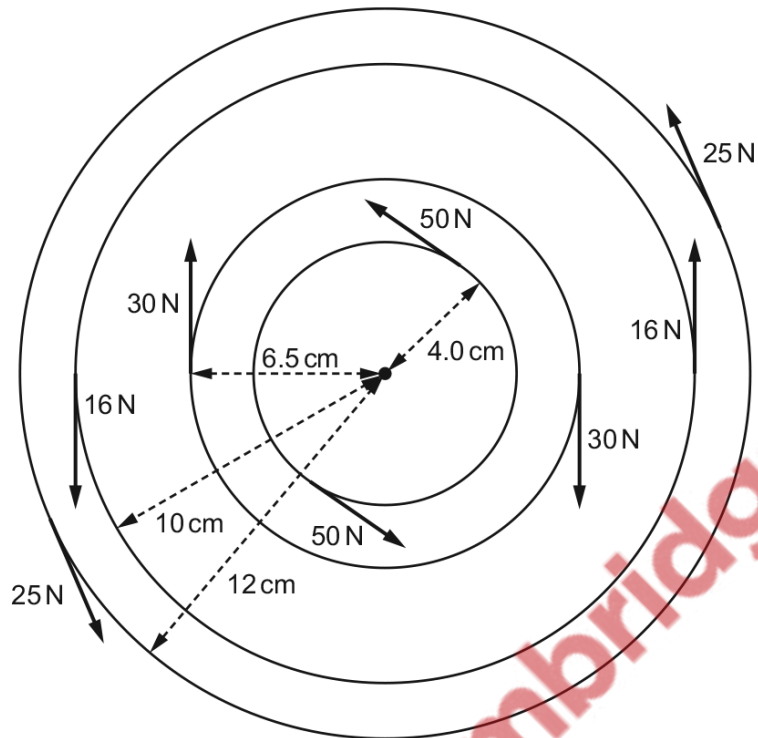

What is the resultant torque acting on the rotating object?

- A** 4.7 Nm **B** 8.6 Nm **C** 9.3 Nm **D** 17.1 Nm



406. 9702_w17_qp_11 Q: 13

A rigid circular disc of radius r has its centre at X . A number of forces of equal magnitude F act at the edge of the disc. All the forces are in the plane of the disc.

Which arrangement of forces provides a moment of magnitude $2Fr$ about X ?

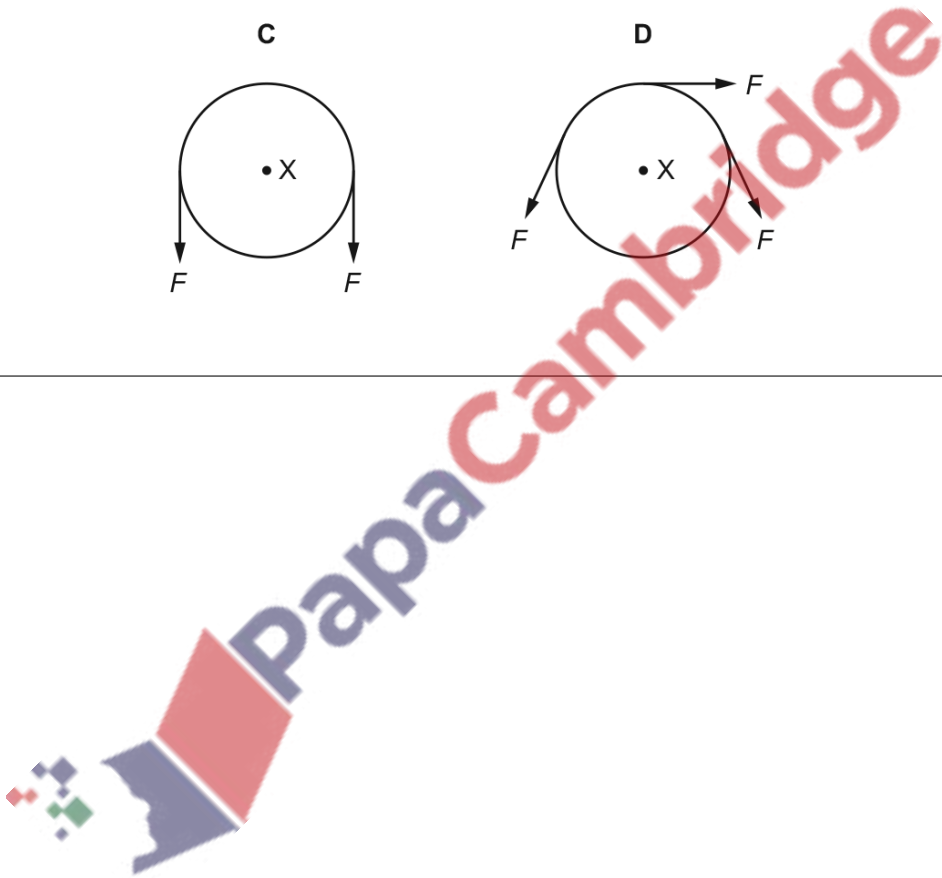
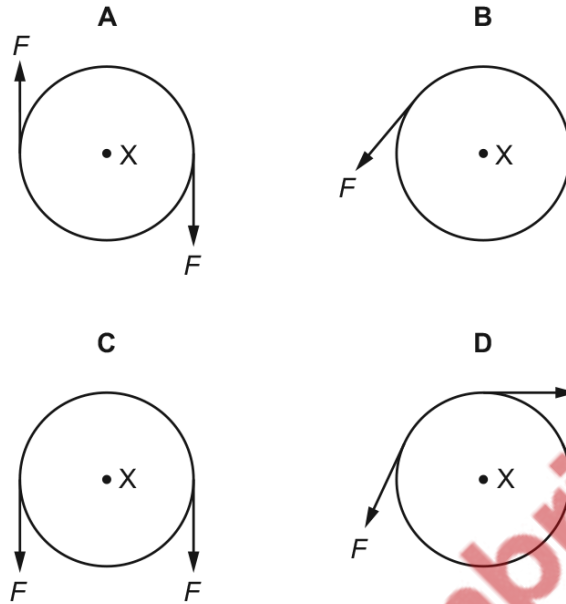

407. 9702_w17_qp_12 Q: 12

The diagram shows a solid cube with weight W and sides of length L . It is supported at rest by a frictionless spindle that passes through the centres of two opposite vertical faces. One of these faces is shaded.

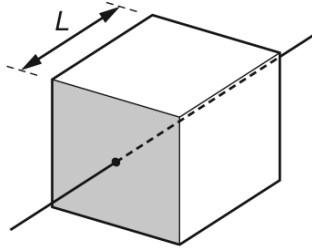

The spindle is now removed and replaced at a distance $\frac{L}{4}$ to the right of its original position.

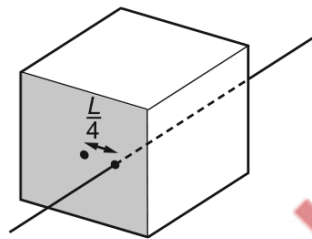

When viewing the shaded face, what is the torque of the couple that will now be needed to keep the cube at rest?

- A $\frac{WL}{4}$ anticlockwise
- B $\frac{WL}{4}$ clockwise
- C $\frac{WL}{2}$ anticlockwise
- D $\frac{WL}{2}$ clockwise

408. 9702_w17_qp_13 Q: 12

Two forces, each of magnitude F , act along the edges of a rectangular metal plate, as shown.

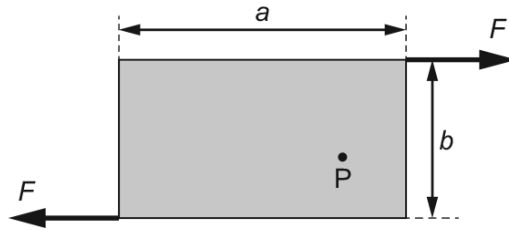

The plate has length a and width b .

What is the torque about point P ?

- A Fa B Fb C $2Fa$ D $2Fb$

409. 9702_m16_qp_12 Q: 13

Two forces, each of magnitude F , act at points V and W on an object.

The two forces form a couple. The shape of the object is a right-angled triangle with sides of lengths x and y , as shown.

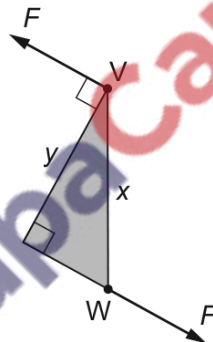

Which expression gives the torque exerted by the couple?

- A Fx B Fy C $2Fx$ D $2Fy$

410. 9702_s16_qp_12 Q: 14

Two coplanar forces act on the rim of a wheel. The forces are equal in magnitude.

Which arrangement of forces provides only a couple?

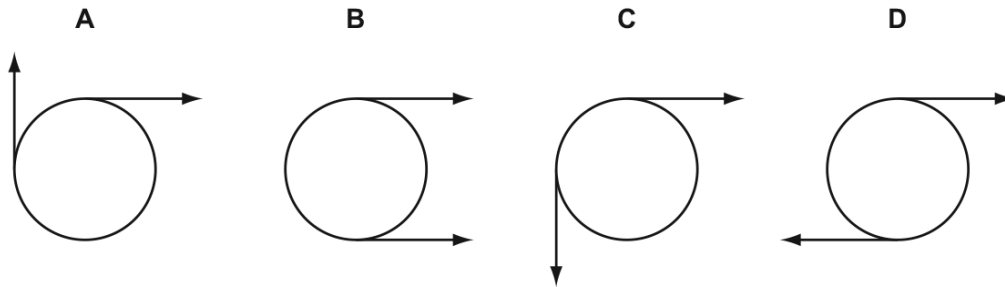

411. 9702_s16_qp_13 Q: 14

A bicycle pedal is connected to a pivot by a metal bar, as shown.

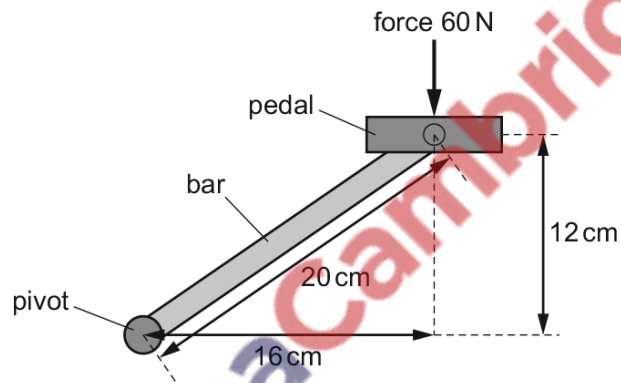

The force on the pedal is 60 N downwards.

What is the moment of this force about the pivot?

- A** 7.2 Nm **B** 9.6 Nm **C** 12 Nm **D** 1200 Nm

412. 9702_w16_qp_12 Q: 15

A minimum torque of 20 N m must be applied to the lid of a jar for it to open. The radius of the lid is 4.0 cm.

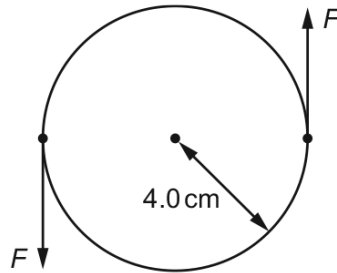

What is the minimum force F that must act on each side of the lid in order to open it?

- A** 2.5 N **B** 5.0 N **C** 250 N **D** 500 N

413. 9702_w16_qp_12 Q: 17

A rigid cross-shaped structure having four arms PO, SO, QO and RO, each 1.00 m long, is pivoted at O. Forces act on the ends of the arms and on the midpoints of the arms as shown.

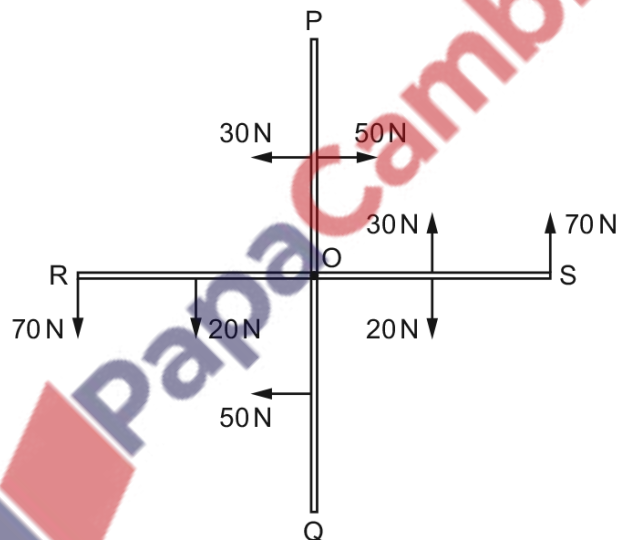

What is the magnitude of the resultant moment on the structure about O?

- A** 45 N m **B** 90 N m **C** 120 N m **D** 190 N m

5.3 Equilibrium of forces

414. 9702_m20_qp_12 Q: 13

Three coplanar forces act on a block.

Which diagram shows the directions of the forces such that the block could be in equilibrium?

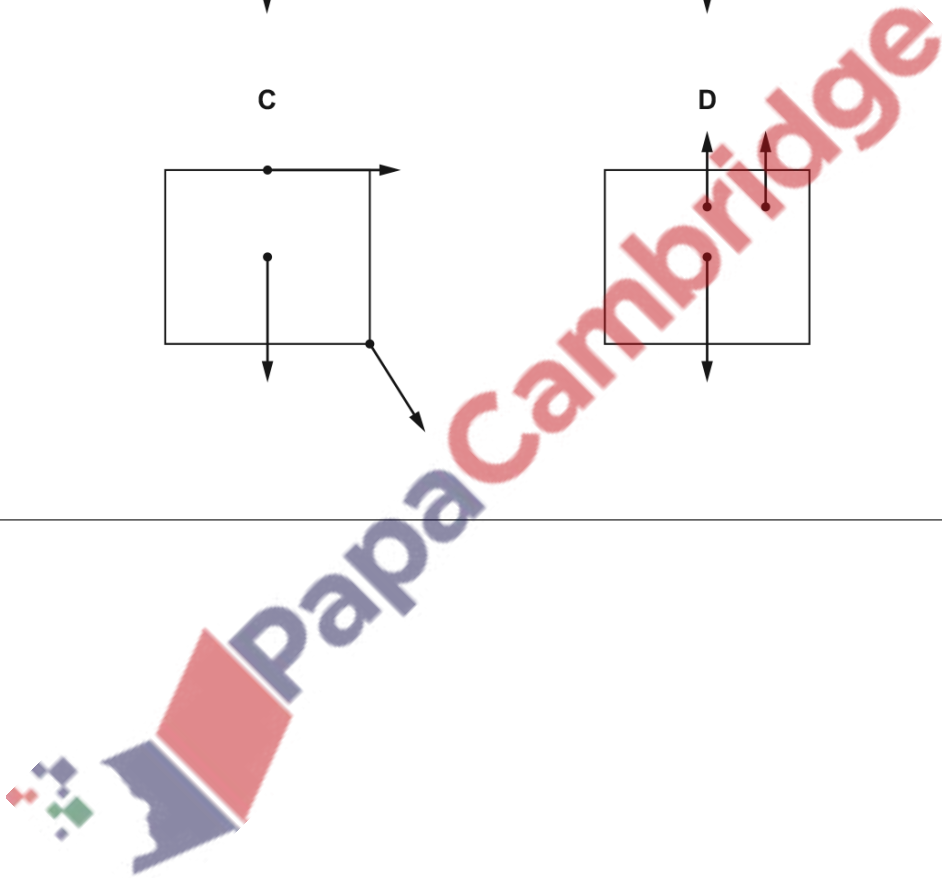
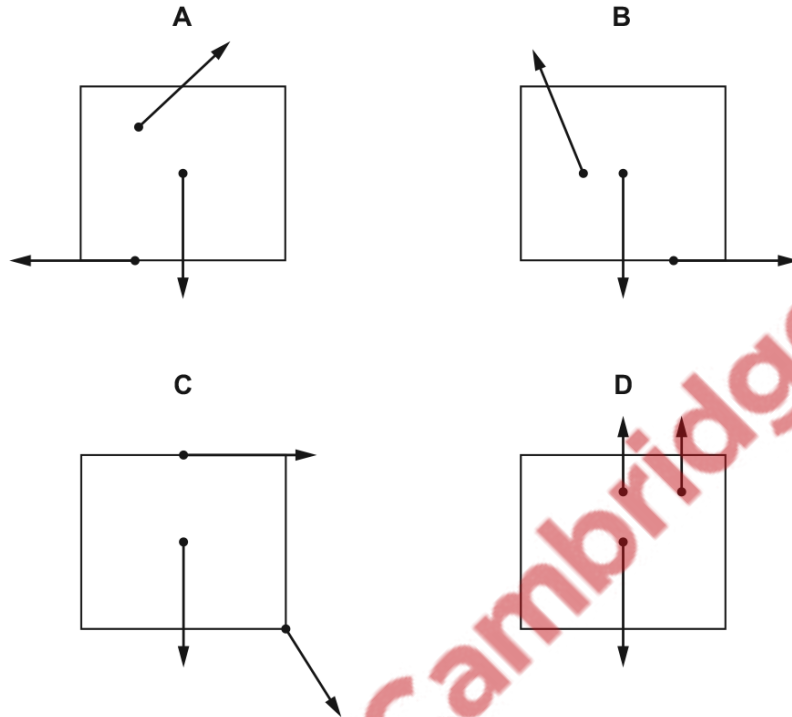

415. 9702_s20_qp_11 Q: 14

Four combinations of vectors are shown, each representing all the forces acting on an object. The forces all act in the same plane.

The object is in equilibrium.

Which combination of vectors could represent the forces acting on the object?

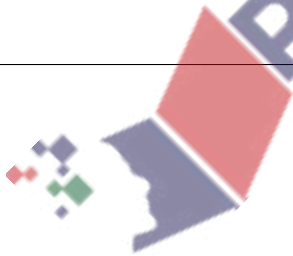
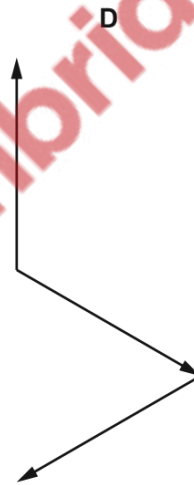
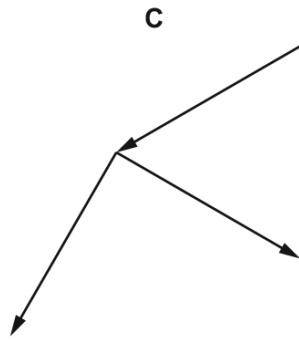
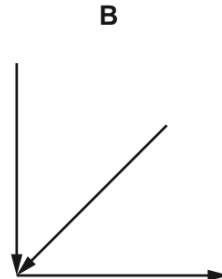
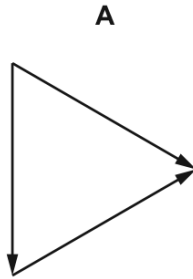

416. 9702_s20_qp_12 Q: 12

A thin horizontal beam XY is freely hinged at point Y to a vertical wall. The beam is held stationary by a cable XZ which is attached to the wall at point Z.

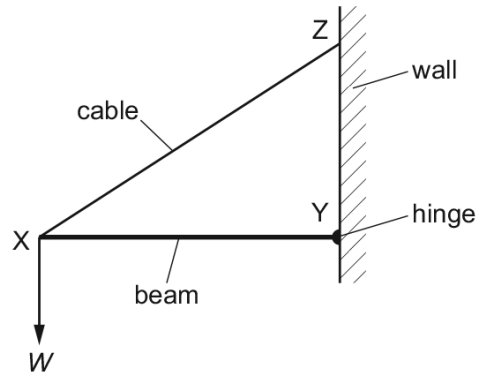

The beam supports a weight W at point X. The forces in the cable and the beam are F_C and F_B respectively.

Which vector triangle represents the forces acting on point X?

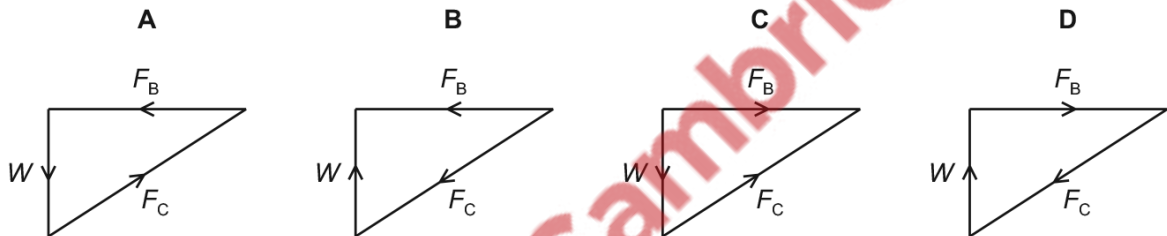

417. 9702_s20_qp_13 Q: 13

A non-uniform rod has a mass of 100 g and a length of 50 cm. It is supported by a chain at its midpoint. The rod is held in equilibrium by having a mass of 60 g suspended from its right-hand end, as shown.

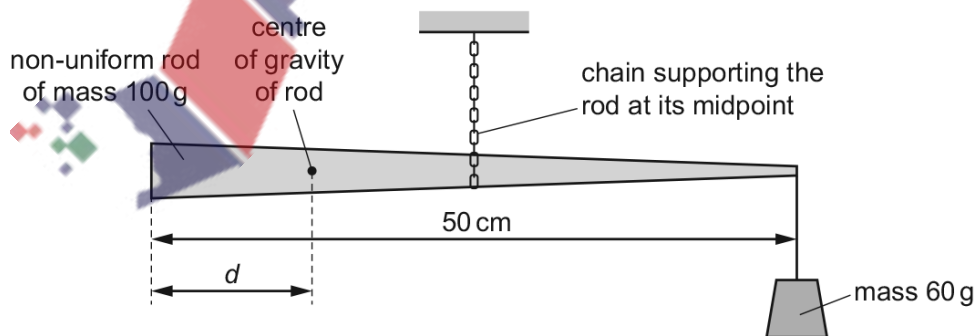

The centre of gravity of the rod is a distance d from its left-hand end.

What is the value of d ?

- A 10 cm B 15 cm C 25 cm D 40 cm

418. 9702_s20_qp_13 Q: 14

A light rigid rod XY has an object of weight W fixed at one end. The rod is in equilibrium, resting on a support at Z and a vertical wall at X . The support exerts a force R on the rod as shown. The diagram shows the directions, but not the magnitudes, of the forces R and W .

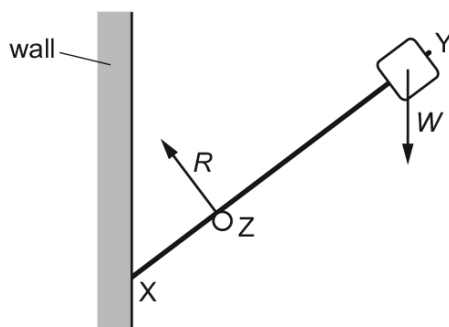

What is the direction of the force on the rod at X ?



419. 9702_s19_qp_11 Q: 14

A crane uses a counterweight to stop it from toppling over when lifting a load, as shown.

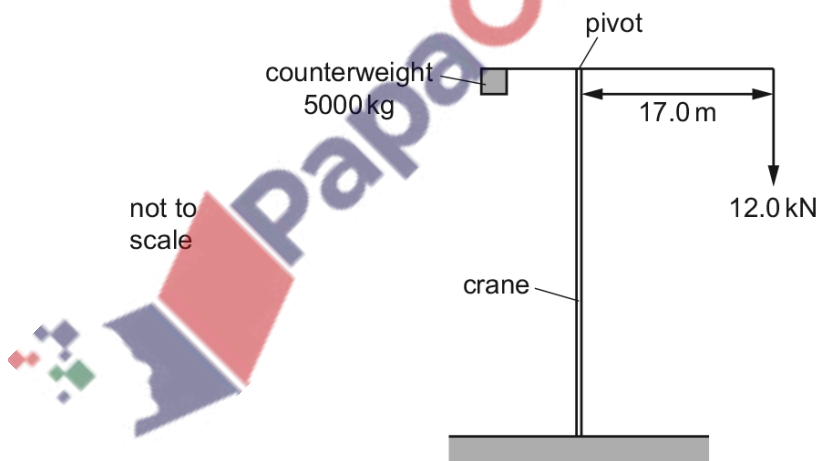

The counterweight has a mass of 5000 kg. The crane is required to lift a load of 12.0 kN and the horizontal distance from the pivot to the load is 17.0 m.

How far from the pivot should the centre of gravity of the counterweight be positioned in order to keep the crane in equilibrium?

- A** 0.0408 m **B** 0.240 m **C** 4.16 m **D** 40.8 m

420. 9702_s19_qp_11 Q: 15

Three parallel forces act on an object. As a result of these forces, the object is in equilibrium.

What **must** be correct for these forces?

- A They all act along the same line.
- B They all have the same magnitude.
- C They do **not** all act along the same line.
- D They do **not** all have the same magnitude.

421. 9702_s19_qp_13 Q: 12

A shop sign weighing 75 N hangs from a frame attached to a vertical wall.

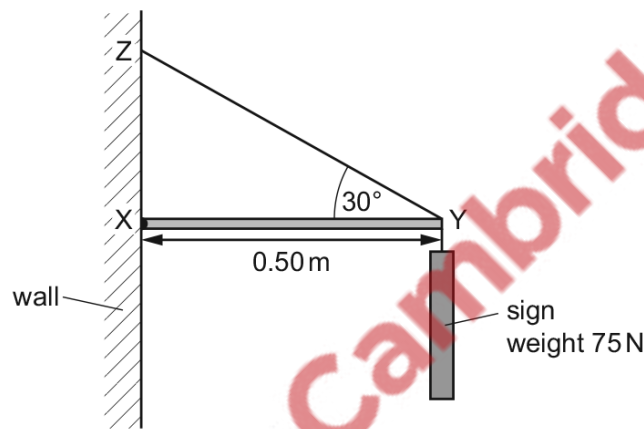

The frame consists of a horizontal rod XY and a rod YZ that is at an angle of 30° to the horizontal. Rod XY is attached to the wall by a hinge at X and has length 0.50 m. Assume that the weights of the rods are negligible.

What is the horizontal force exerted by the wall on rod XY?

- A 0 N
- B 43 N
- C 130 N
- D 150 N

422. 9702_w19_qp_11 Q: 13

An object of weight 120 N is supported in equilibrium by two strings as shown.

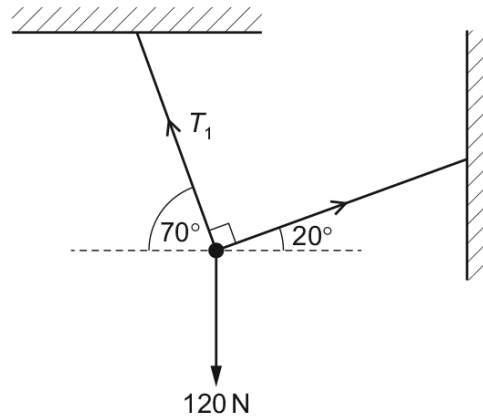

What is the tension T_1 in the left-hand string?

- A** 41 N **B** 77 N **C** 113 N **D** 128 N

423. 9702_w19_qp_12 Q: 11

A rigid uniform bar of length 2.4 m is pivoted horizontally at its midpoint.

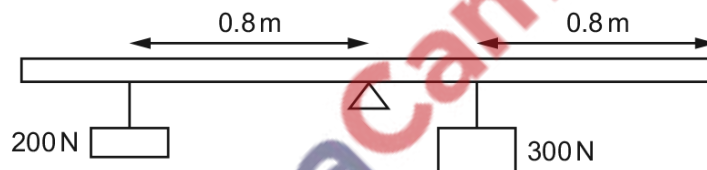

Weights are hung from two points on the bar as shown in the diagram. To maintain equilibrium, a couple is applied to the bar.

What is the torque and direction of this couple?

- A** 40 N m clockwise
B 40 N m anticlockwise
C 80 N m clockwise
D 80 N m anticlockwise

424. 9702_w19_qp_12 Q: 12

Two coplanar forces act on an object as shown.

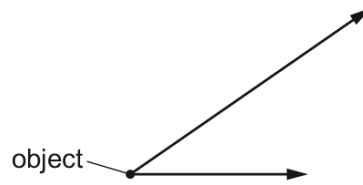

Which diagram shows the resultant F of these two forces?

A

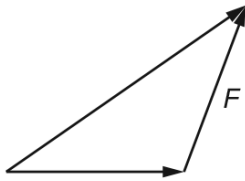

B

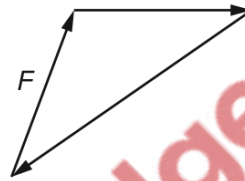

C

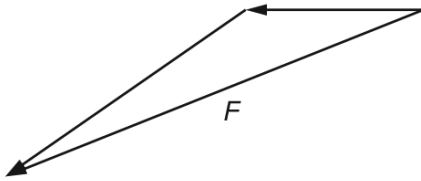

D

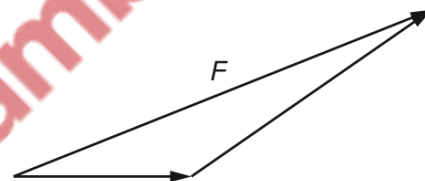

425. 9702_w19_qp_13 Q: 12

A heavy ball hanging from a cable is held in equilibrium by a chain, as shown.

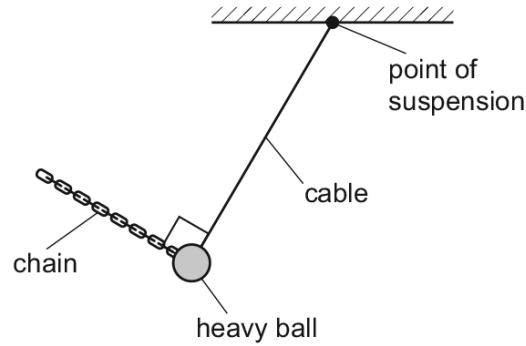

Which vector diagram shows the three forces acting on the ball?

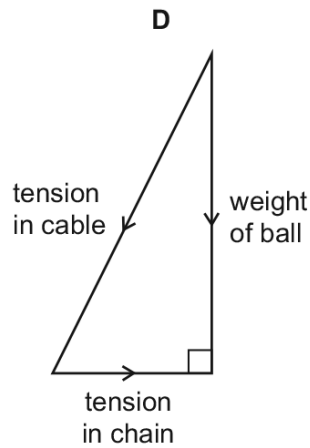
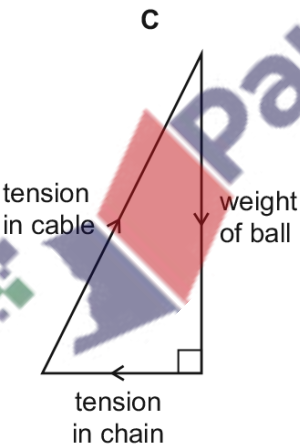
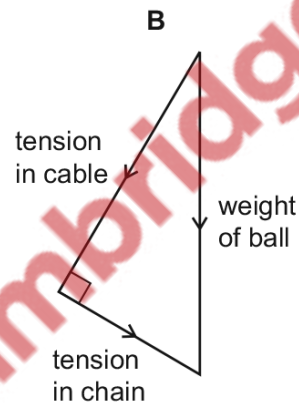
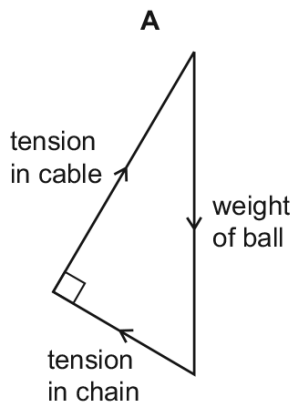

426. 9702_m18_qp_12 Q: 13

In which example is it **not** possible for the underlined body to be in equilibrium?

- A An aeroplane climbs at a steady rate.
- B An aeroplane tows a glider at a constant altitude.
- C A speedboat changes direction at a constant speed.
- D Two boats tow a ship into harbour.

427. 9702_s18_qp_12 Q: 15

The vector diagram shows three coplanar forces acting on an object at P.

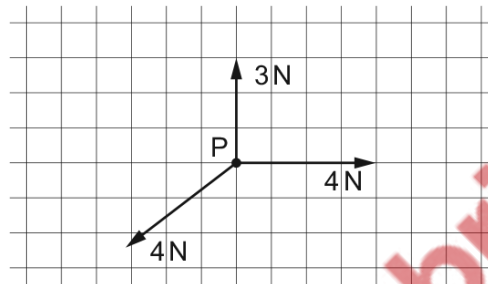

The magnitude of the resultant of these three forces is 1 N.

What is the direction of this resultant force?

- A 
- B 
- C 
- D 



428. 9702_s18_qp_12 Q: 17

The diagram shows a ball of weight W hanging in equilibrium from a string.

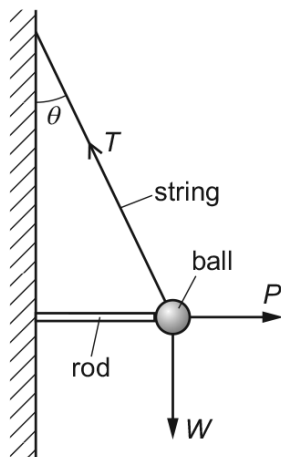

The string is at an angle θ to the vertical. The tension in the string is T . The ball is held away from the wall by a horizontal force P from a metal rod.

What is the relationship between the magnitudes of T , P and W ?

- A $P = T \cos \theta$ and $W = T \sin \theta$
- B $T = P + W$
- C $T^2 = P^2 + W^2$
- D $W = P \tan \theta$ and $W = T \cos \theta$

429. 9702_w18_qp_11 Q: 11

A uniform rod of length 200 cm is freely pivoted at point P. The rod is held horizontally in equilibrium by a 60 N weight that is attached to the rod by a string passing over a frictionless pulley.

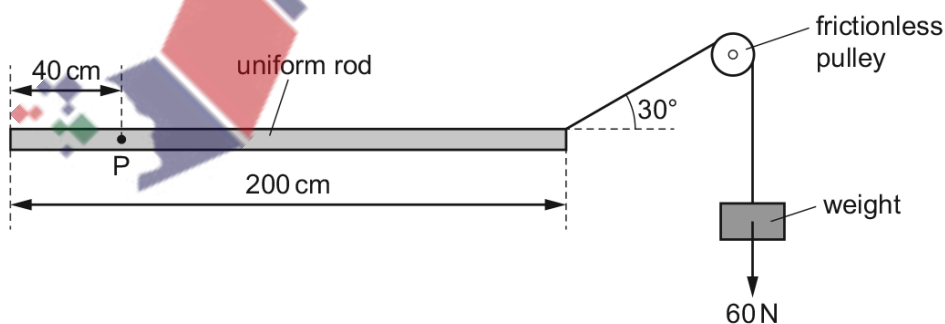

What is the weight of the rod?

- A 30 N
- B 60 N
- C 80 N
- D 140 N

430. 9702_w18_qp_11 Q: 12

A ladder rests in equilibrium on rough ground against a rough wall.

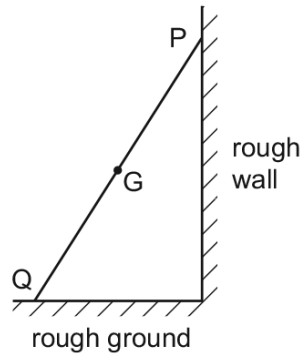

The weight W of the ladder acts through the centre of gravity G . Forces also act on the ladder at P and at Q . These forces are P and Q respectively.

Which vector triangle represents the forces on the ladder?

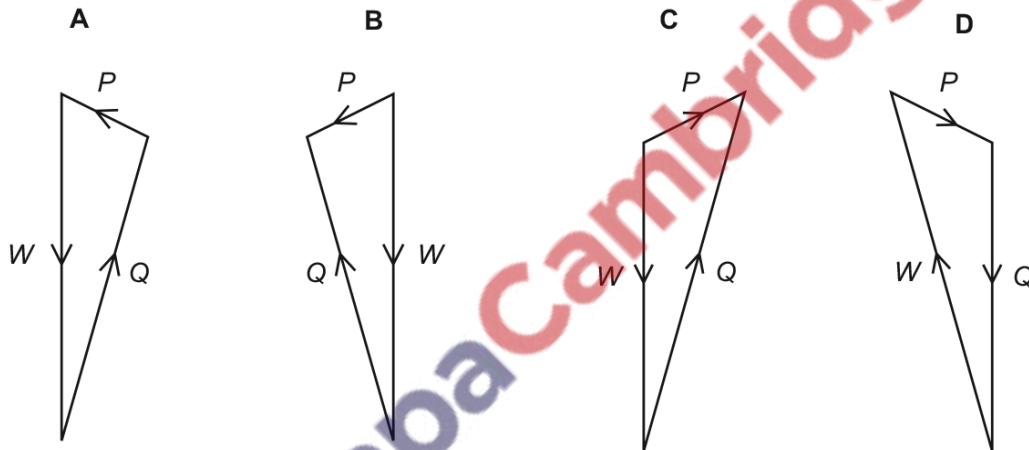

431. 9702_w18_qp_12 Q: 12

A uniform rectangular board is supported by a frictionless pivot at its centre point P.

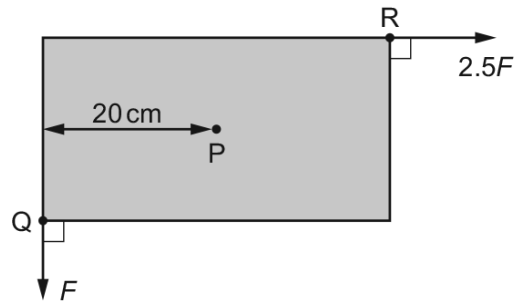

Two forces act in the plane of the board. Force F acts at corner Q and force $2.5F$ acts at corner R. The perpendicular distance between the line of action of force F and point P is 20 cm. The board is in equilibrium.

What is the area of the board?

- A** 160 cm^2 **B** 320 cm^2 **C** 640 cm^2 **D** 1600 cm^2

432. 9702_w18_qp_12 Q: 13

A kite is in equilibrium at the end of a string, as shown.

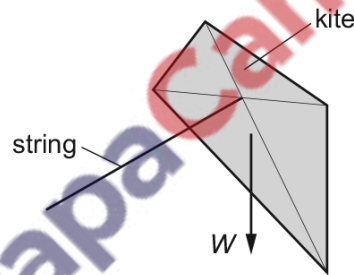

The kite has three forces acting on it: the weight W , the tension T in the string, and the force F from the wind.

Which vector diagram represents the forces acting on the kite?



433. 9702_w18_qp_13 Q: 13

The diagram shows the jib of a crane at an angle of 35° to the vertical. A cable passes over a frictionless pulley and carries a load of 1830 N.

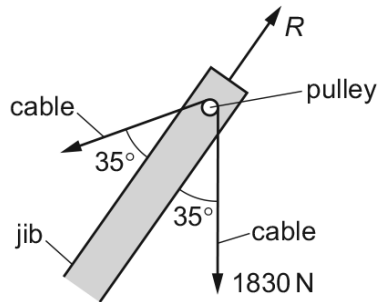

The force R that the pulley exerts on the cable is in line with the jib. The cable and the pulley are in equilibrium.

What is the value of R ?

- A** 1000 N **B** 1500 N **C** 2100 N **D** 3000 N

434. 9702_m17_qp_12 Q: 11

A spherical object falls through water at constant speed. Three forces act on the object.

Which diagram, showing these three forces to scale, is correct?

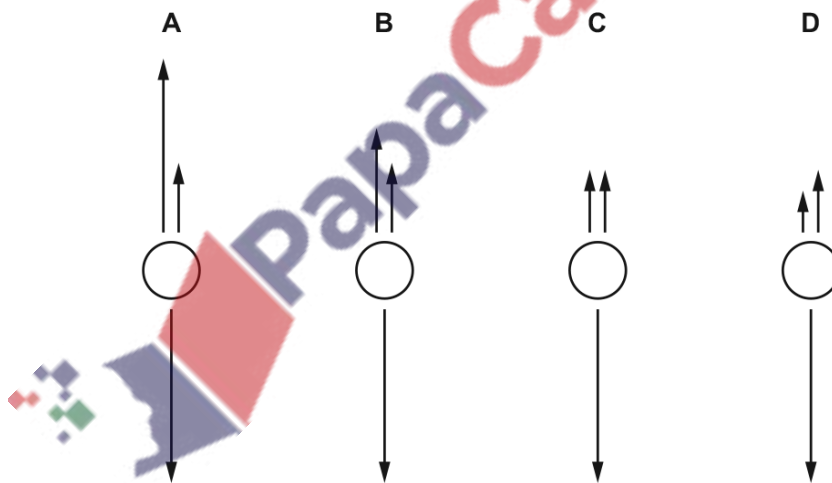

435. 9702_m17_qp_12 Q: 14

An object hangs by means of two cords around two rods, as shown.

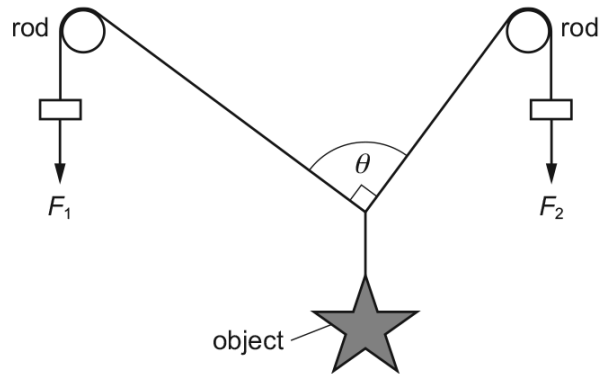

The object is held in equilibrium by the forces F_1 and F_2 . The object weighs 10 N. There is negligible friction between the rods and cords. Angle θ is 90° .

Which row of the table gives an angle θ of 90° ?

	F_1 /N	F_2 /N
A	4.0	6.0
B	6.0	4.0
C	6.0	8.0
D	8.0	6.0

436. 9702_s17_qp_11 Q: 13

A uniform horizontal footbridge is 12 m long and weighs 4000 N. It rests on two supports X and Y as shown.

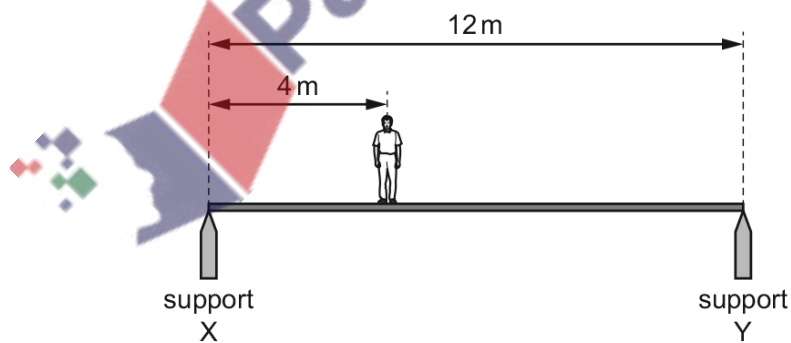

A man of weight 600 N is a distance of 4 m from support X.

What is the upward force on the footbridge from support X?

- A** 2200 N **B** 2300 N **C** 2400 N **D** 2600 N

437. 9702_s17_qp_12 Q: 12

A uniform beam is pivoted at P as shown. Weights of 10 N and 20 N are attached to its ends.

The length of the beam is marked at 0.1 m intervals. The weight of the beam is 100 N.

At which point should a further weight of 20 N be attached to achieve equilibrium?

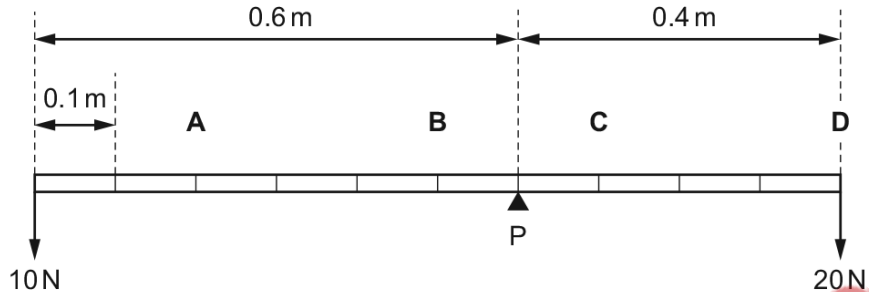

438. 9702_s17_qp_13 Q: 11

A uniform beam of mass 1.4 kg is pivoted at P as shown. The beam has a length of 0.60 m and P is 0.20 m from one end. Loads of 3.0 kg and 6.0 kg are suspended 0.35 m and 0.15 m from the pivot as shown.

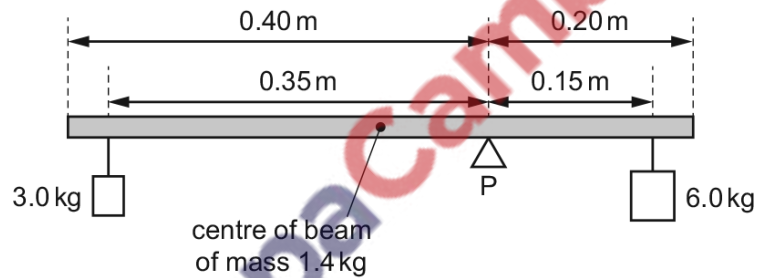

What is the torque that must be applied to the beam in order to maintain it in equilibrium?

- A** 0.010 Nm **B** 0.10 Nm **C** 0.29 Nm **D** 2.8 Nm



439. 9702_s17_qp_13 Q: 13

The diagram represents a sphere under water. P, Q, R and S are forces acting on the sphere due to the pressure of the water.

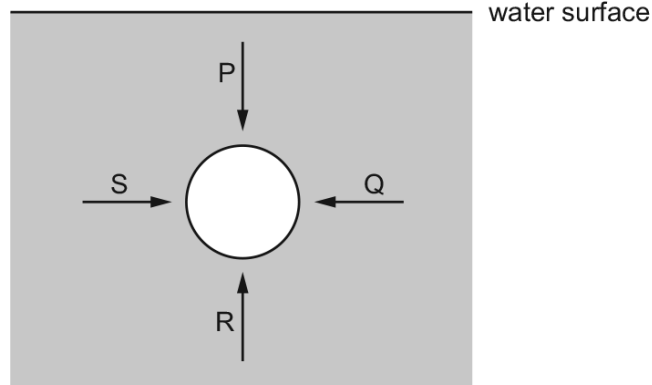

Each force acts perpendicularly to the sphere's surface. P and R act in opposite directions vertically. Q and S act in opposite directions horizontally.

Which information about the magnitudes of the forces is correct?

- A $P < R$ and $S = Q$
- B $P > R$ and $S = Q$
- C $P = R$ and $S = Q$ and $P < S$
- D $P = R$ and $S = Q$ and $P = S$

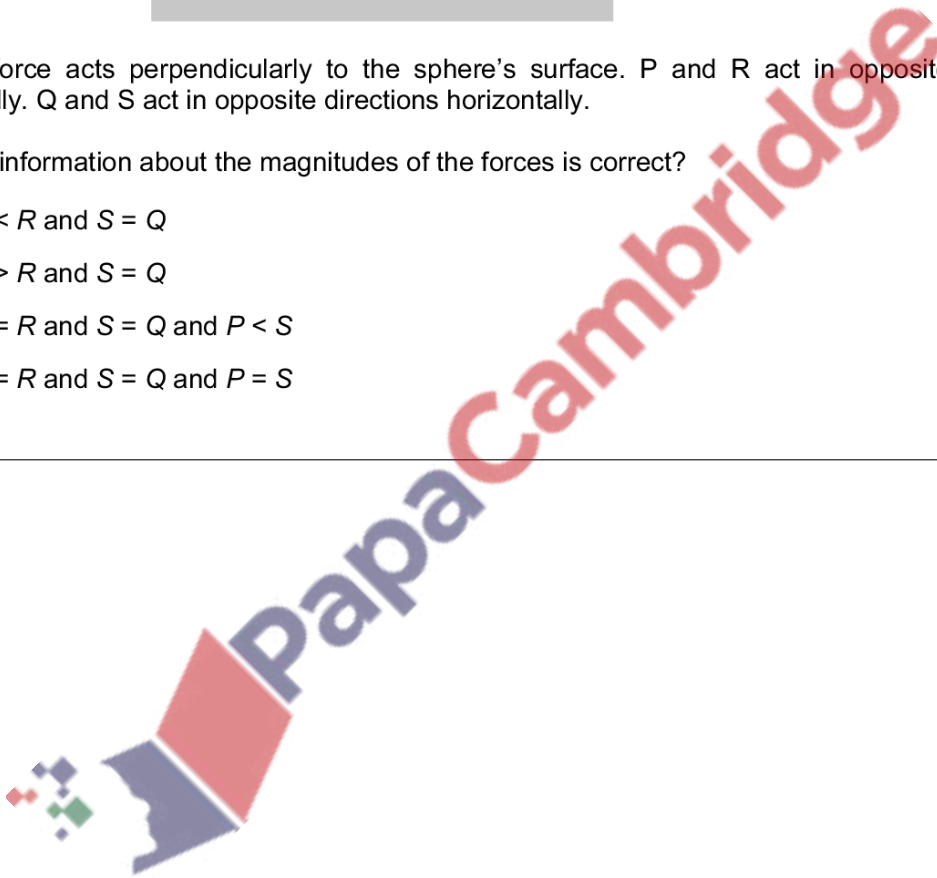

440. 9702_w17_qp_11 Q: 14

The diagram shows a motorised vehicle for carrying one person.

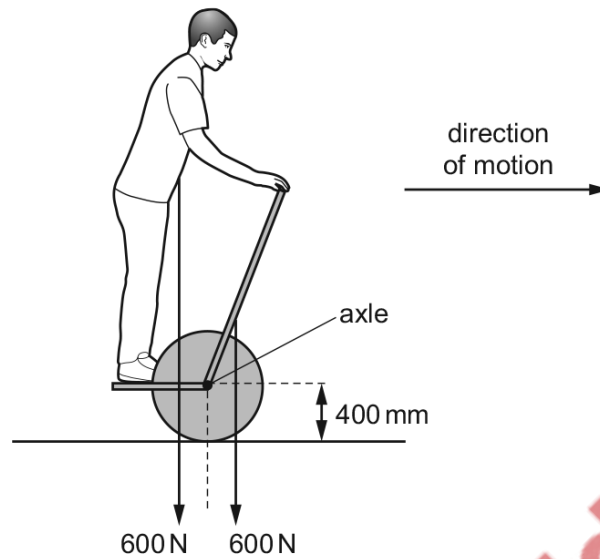

The vehicle has two wheels on one axle. The passenger stands on a platform between the wheels.

The weight of the machine is 600 N. Its centre of mass is 200 mm in front of the axle. The wheel radius is 400 mm.

When stationary, a passenger of weight 600 N stands with his centre of mass 200 mm behind the axle to balance the machine.

The motor is now switched on to provide a horizontal force of 90 N at the ground to move the vehicle forwards.

How far and in which direction must the passenger move his centre of mass to maintain balance?

- A 60 mm backwards
- B 60 mm forwards
- C 140 mm backwards
- D 140 mm forwards

441. 9702_w17_qp_12 Q: 13

A street lamp is fixed to a wall by a metal rod and a cable.

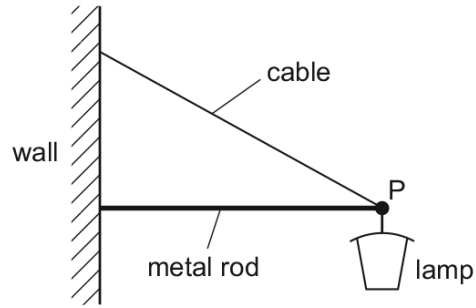

Which vector triangle could represent the forces acting at point P?

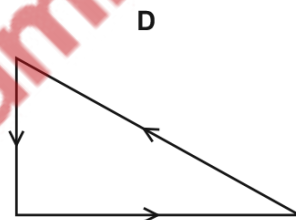
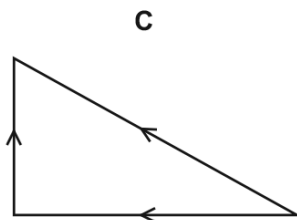
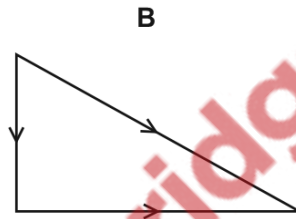
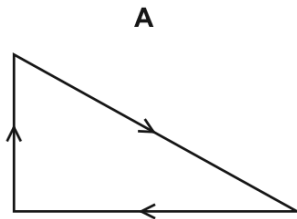

442. 9702_w17_qp_12 Q: 14

Two rigid steel beams XY and YZ are fixed at their lower ends and are hinged at Y. Each beam is inclined at 50° to the horizontal, as shown. A weight of $4.0 \times 10^4 \text{ N}$ hangs from Y. The structure is in equilibrium.

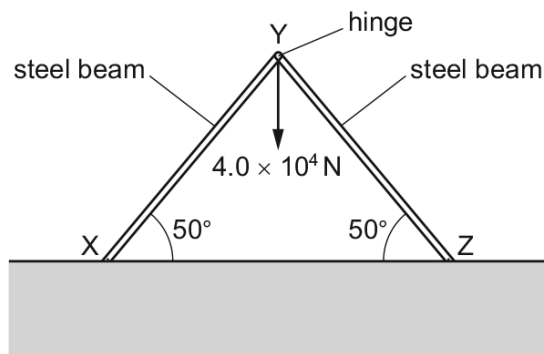

What is the force exerted by each beam on the hinge at Y?

- A $2.6 \times 10^4 \text{ N}$ B $3.1 \times 10^4 \text{ N}$ C $5.2 \times 10^4 \text{ N}$ D $6.2 \times 10^4 \text{ N}$

443. 9702_m16_qp_12 Q: 12

The diagram shows a uniform beam PQ. The length of the beam is 3.0 m and its weight is 50 N. The beam is supported on a pivot 1.0 m from end P. A load of weight W is hung from end P and the beam is in equilibrium.

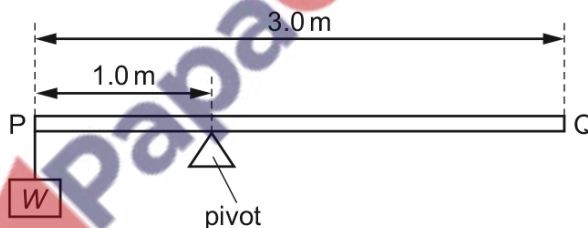

What is the value of W ?

- A 25 N B 50 N C 75 N D 100 N

444. 9702_s16_qp_11 Q: 11

The diagram shows a man standing on a platform that is attached to a flexible pipe. Water is pumped through the pipe so that the man and platform remain at a constant height.

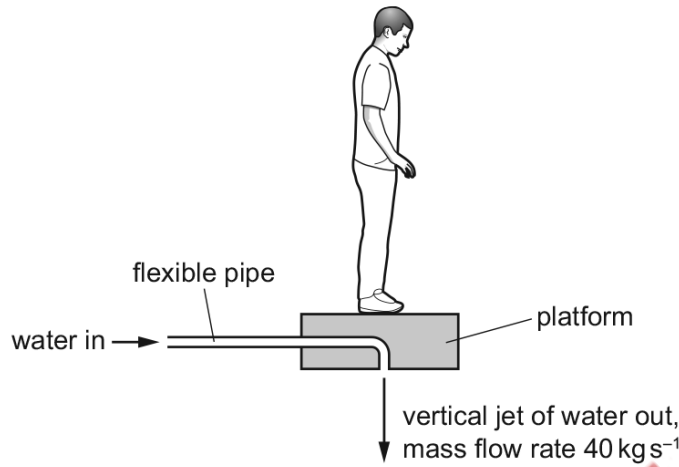

The resultant vertical force on the platform is zero. The combined mass of the man and platform is 96 kg . The mass of water that is discharged vertically downwards from the platform each second is 40 kg .

What is the speed of the water leaving the platform?

- A** 2.4 ms^{-1} **B** 6.9 ms^{-1} **C** 24 ms^{-1} **D** 47 ms^{-1}

445. 9702_s16_qp_11 Q: 12

Forces are applied to a rigid body. The forces all act in the same plane.

In which diagram is the body in equilibrium?

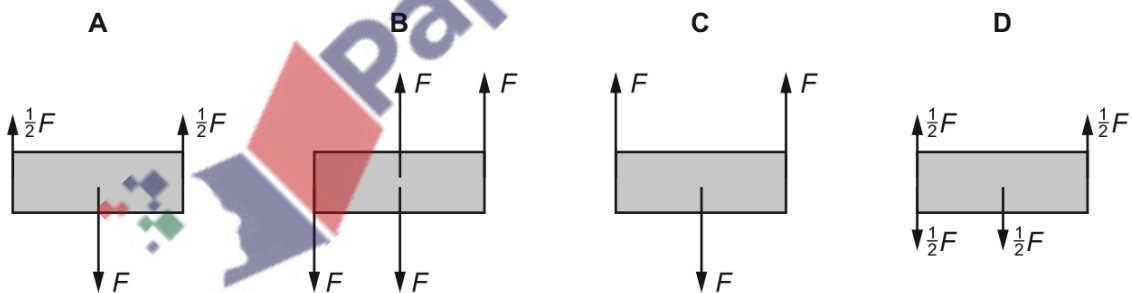

446. 9702_s16_qp_11 Q: 14

A trailer of weight 30 kN is attached to a cab at X, as shown in the diagram.

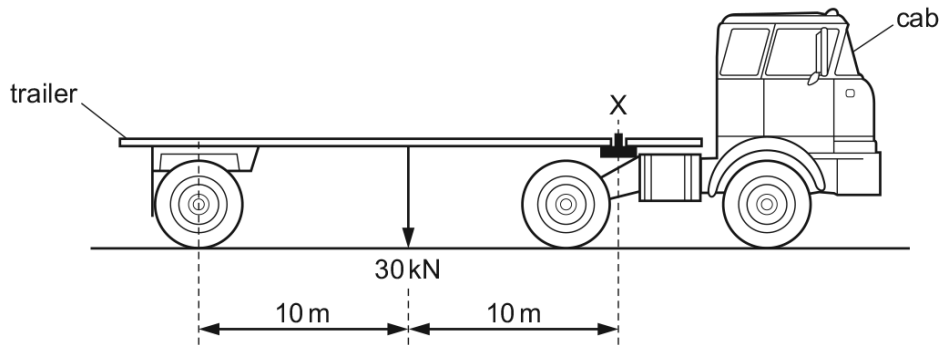

What is the upward force exerted at X by the cab on the trailer?

- A** 3 kN **B** 15 kN **C** 30 kN **D** 60 kN

447. 9702_s16_qp_12 Q: 12

A light rigid rod XY has an object of weight W fixed at one end. The rod is in equilibrium, resting on a roller at Z and a vertical wall at X. The roller exerts a force R on the rod as shown. The diagram shows the directions, but not the magnitudes, of the forces R and W .

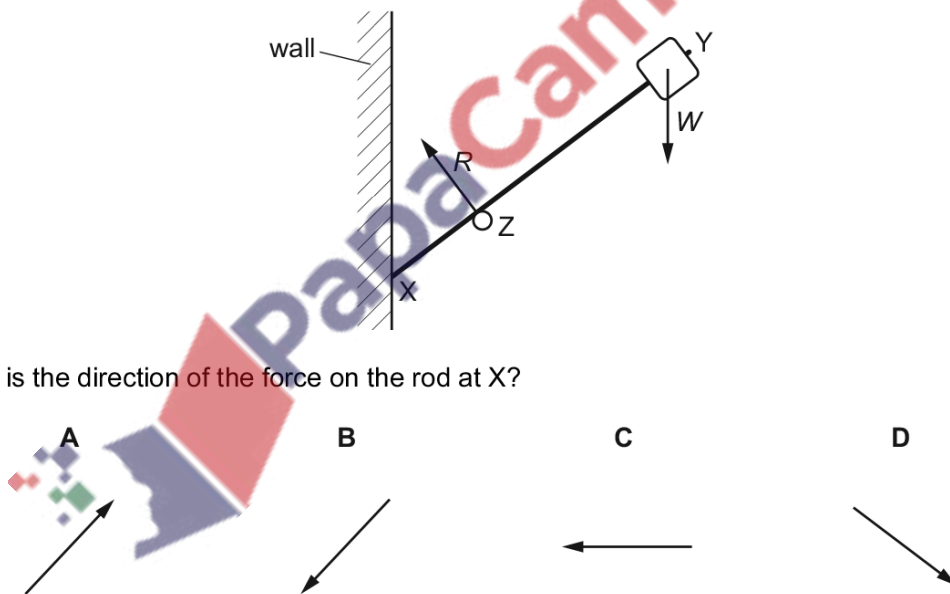

What is the direction of the force on the rod at X?

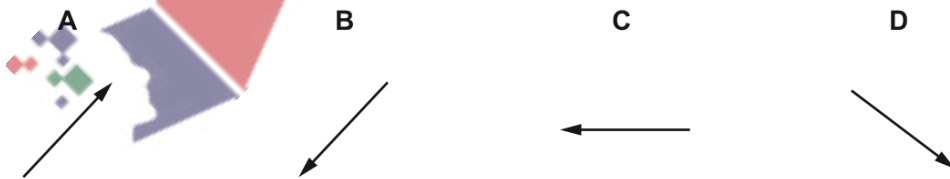

448. 9702_w16_qp_11 Q: 15

Four beams of the same length each have three forces acting on them.

Which beam has both zero resultant force and zero resultant torque acting?

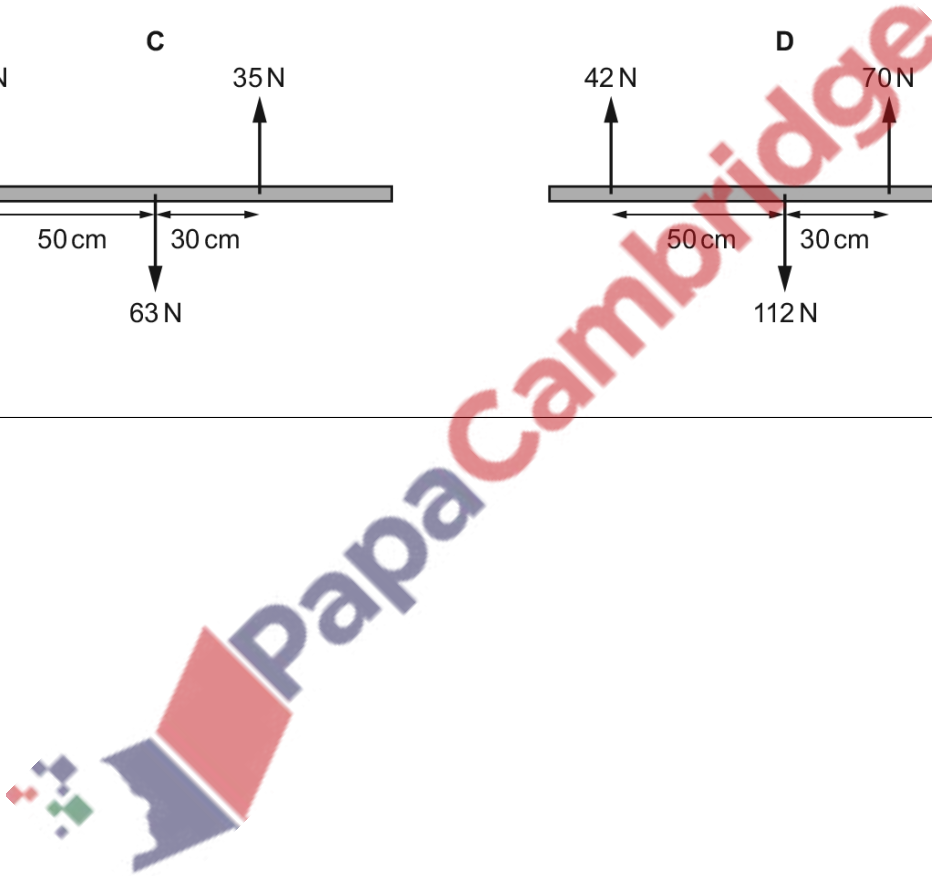
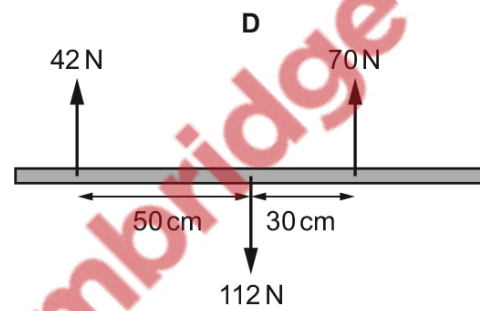
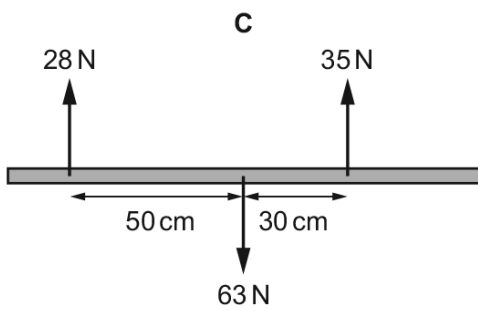
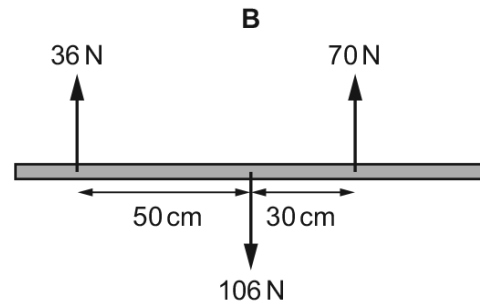
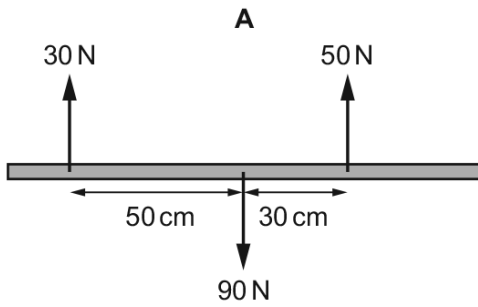

449. 9702_w16_qp_11 Q: 16

An air-conditioning unit is supported by a rigid beam PQ, as shown.

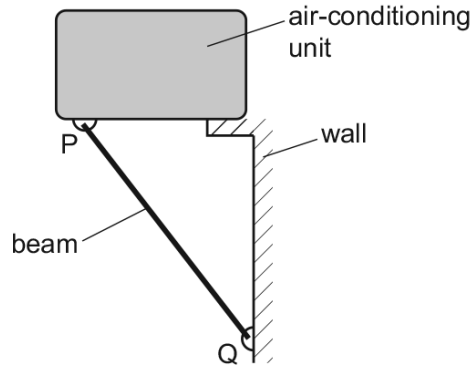

Which diagram shows the directions of the horizontal and vertical forces acting on the ends of the beam?

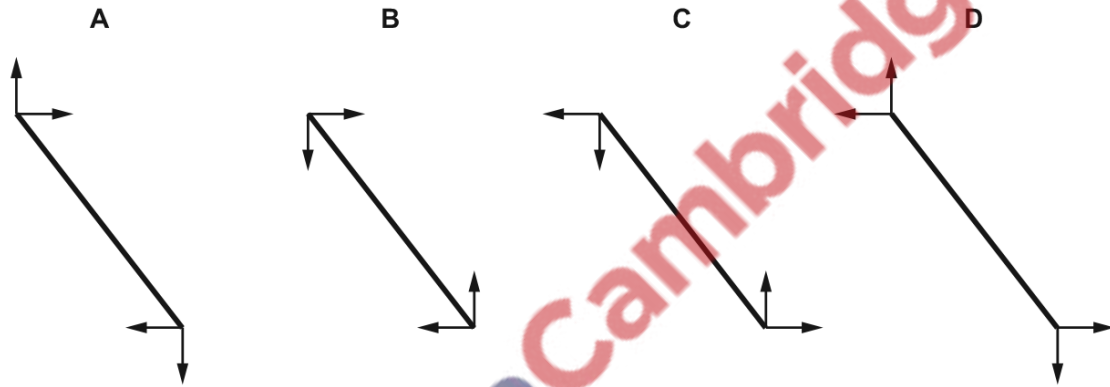

450. 9702_w16_qp_13 Q: 15

Four beams of the same length each have three forces acting on them.

Which beam has both zero resultant force and zero resultant torque acting?

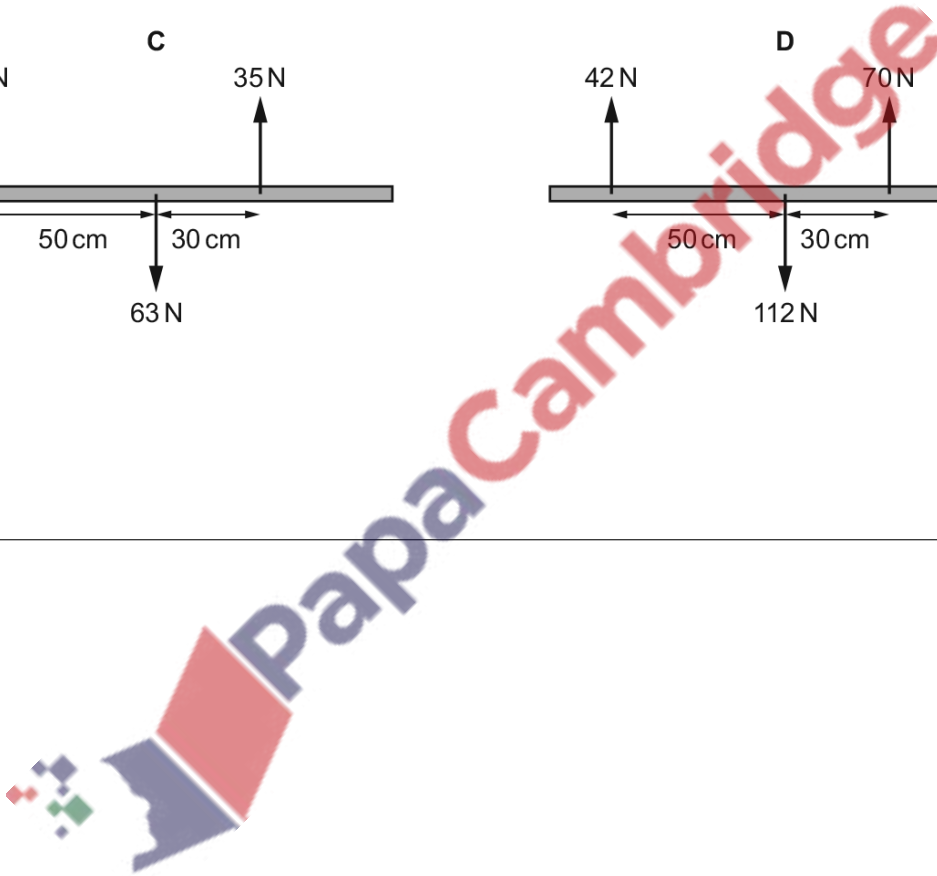
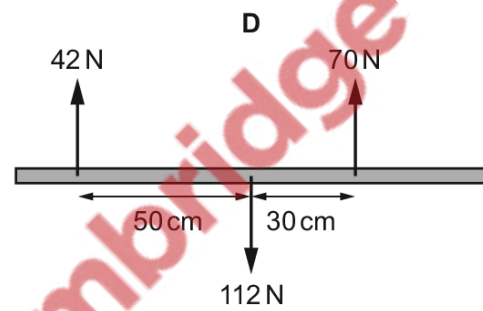
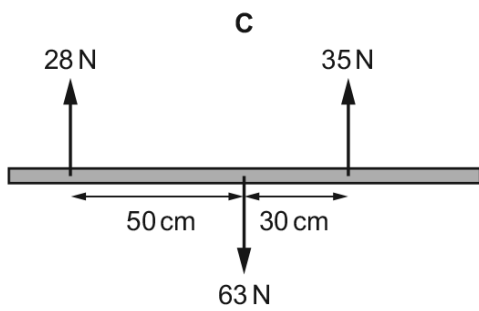
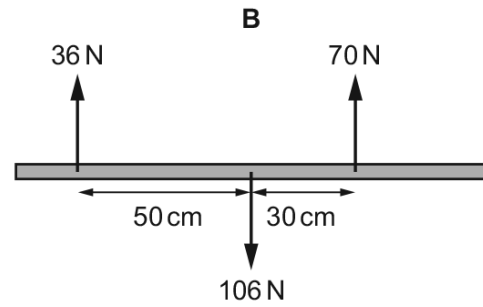
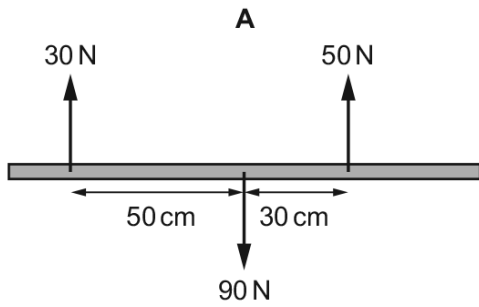

451. 9702_w16_qp_13 Q: 16

An air-conditioning unit is supported by a rigid beam PQ, as shown.

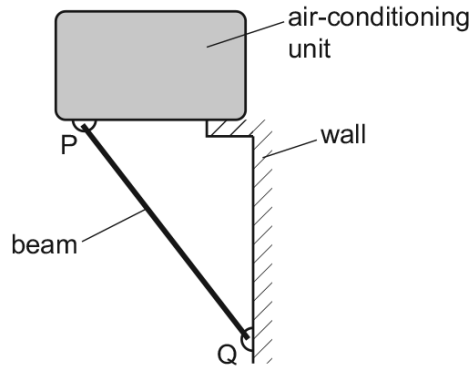

Which diagram shows the directions of the horizontal and vertical forces acting on the ends of the beam?

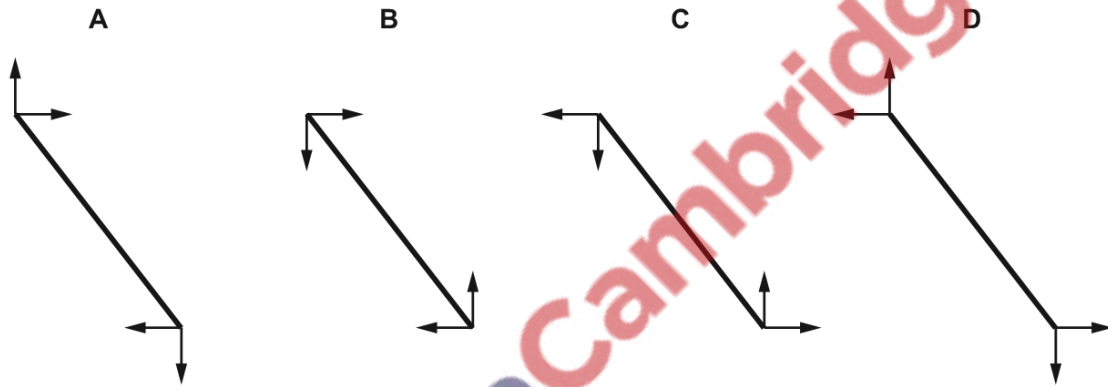

452. 9702_s15_qp_11 Q: 15

A uniform metre rule is pivoted at the 34.0 cm mark, as shown.

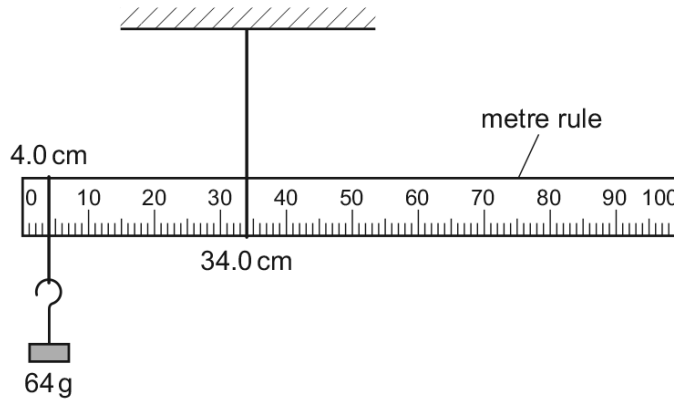

The rule balances when a 64 g mass is hung from the 4.0 cm mark.

What is the mass of the metre rule?

- A** 38 g **B** 44 g **C** 120 g **D** 136 g

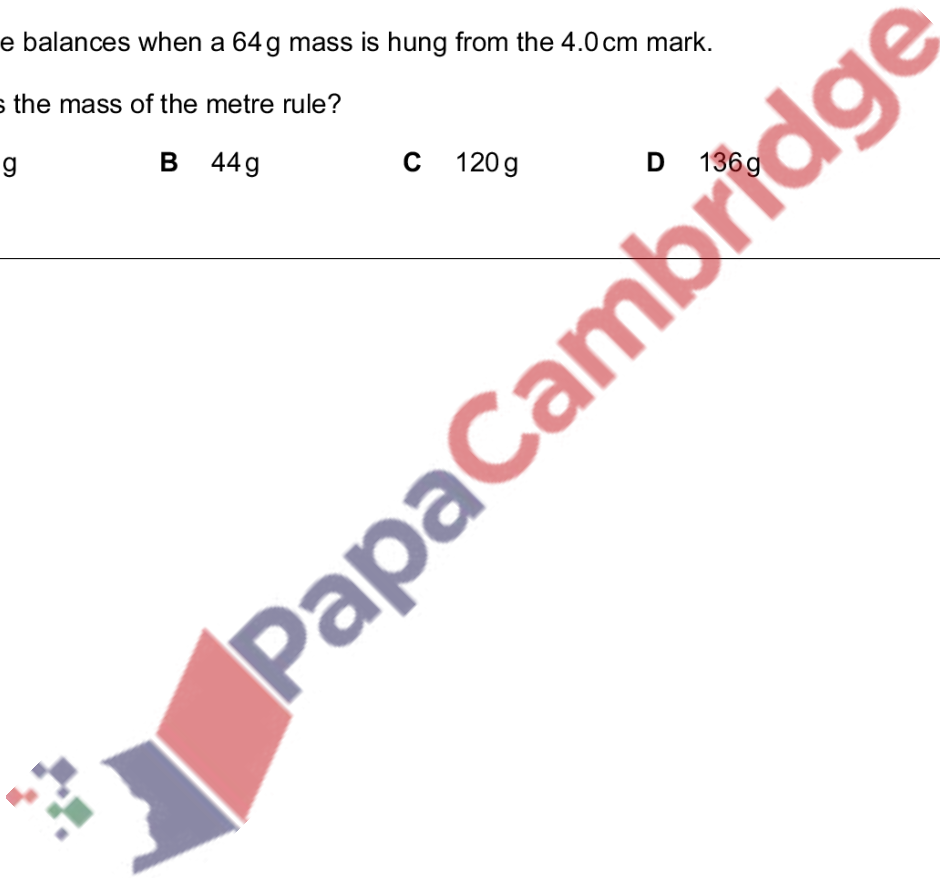

453. 9702_s15_qp_12 Q: 14

A ladder is positioned on icy (frictionless) ground and is leant against a rough wall. At the instant of release it begins to slide.

Which diagram correctly shows the directions of the forces P , W and R acting on the ladder as it slides?

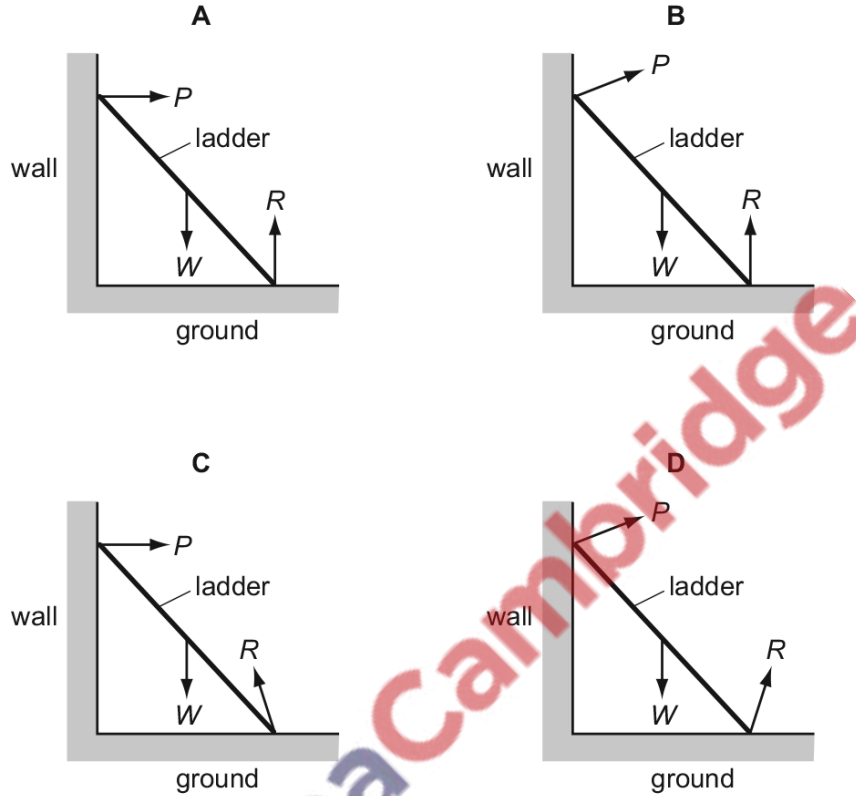

454. 9702_s15_qp_13 Q: 16

The diagrams represent systems of coplanar forces acting at a point. The lengths of the force vectors represent the magnitudes of the forces.

Which system of forces is in equilibrium?

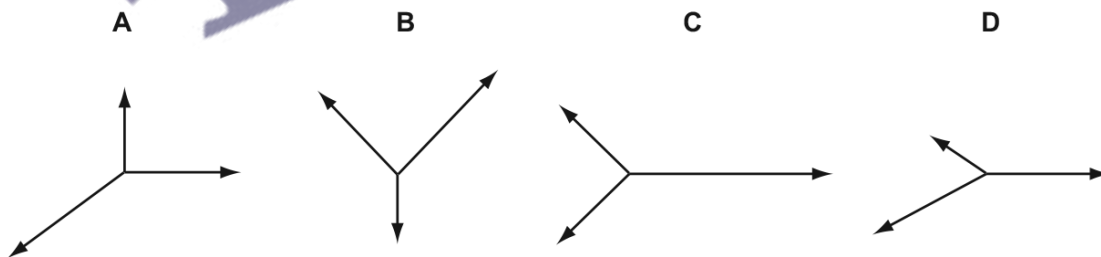

5.4 Density and pressure

455. 9702_s20_qp_11 Q: 15

A rectangular metal bar exerts a pressure of 15 200 Pa on the horizontal surface on which it rests.

The height of the metal bar is 80 cm.

What is the density of the metal?

- A 190 kg m^{-3}
- B 1900 kg m^{-3}
- C $19\,000 \text{ kg m}^{-3}$
- D $190\,000 \text{ kg m}^{-3}$

456. 9702_s20_qp_12 Q: 13

A pipe, open at one end, floats in a liquid as shown.

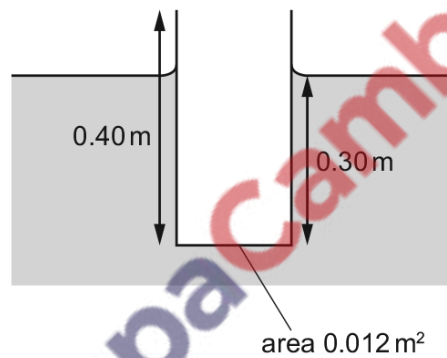

The cross-sectional area of the pipe is 0.012 m^2 . The weight of the pipe is 32 N.

What is the density of the liquid?

- A 680 kg m^{-3}
- B 910 kg m^{-3}
- C 6700 kg m^{-3}
- D 8900 kg m^{-3}

457. 9702_s20_qp_13 Q: 11

A submarine is in equilibrium in a fully submerged position.

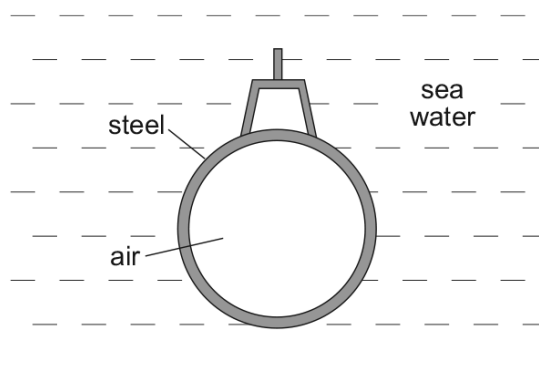

What causes the upthrust on the submarine?

- A The air in the submarine is less dense than sea water.
- B There is a difference in water pressure acting on the top and on the bottom of the submarine.
- C The sea water exerts a greater upward force on the submarine than the weight of the steel.
- D The submarine displaces its own volume of sea water.

458. 9702_s20_qp_13 Q: 15

Liquid Q has twice the density of liquid R.

At depth x in liquid R, the pressure due to the liquid is 4 kPa.

At which depth in liquid Q is the pressure due to the liquid 7 kPa?

- A $\frac{2x}{7}$
- B $\frac{7x}{8}$
- C $\frac{8x}{7}$
- D $\frac{7x}{2}$

459. 9702_m19_qp_12 Q: 14

An object shaped as a hemisphere rests with its flat surface on a table. The object has radius r and density ρ .

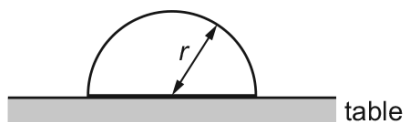

The volume of a sphere is $\frac{4}{3}\pi r^3$.

Which average pressure does the object exert on the table?

- A $\frac{1}{3}\rho r^2$
- B $\frac{1}{3}\rho r^2 g$
- C $\frac{2}{3}\rho r$
- D $\frac{2}{3}\rho r g$

460. 9702_s19_qp_11 Q: 12

A cylindrical iceberg of height H floats in sea water. The top of the iceberg is at height h above the surface of the water.

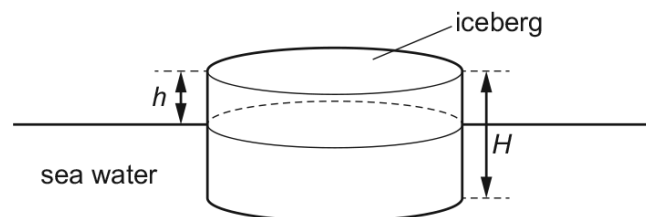

The density of ice is ρ_i and the density of sea water is ρ_w .

What is the height h of the iceberg above the sea water?

- A $\left(1 - \frac{\rho_i}{\rho_w}\right)H$ B $\left(\frac{\rho_i}{\rho_w} - 1\right)H$ C $\frac{\rho_w}{\rho_i}H$ D $\frac{\rho_i}{\rho_w}H$

461. 9702_s19_qp_11 Q: 16

An empty glass beaker has a mass of 103 g. When filled with water, it has a total mass of 361 g. When filled with cooking oil, it has a total mass of 351 g.

The density of water is 1.00 g cm^{-3} .

What is the density of the cooking oil?

- A 0.961 g cm^{-3} B 0.972 g cm^{-3} C 1.03 g cm^{-3} D 1.04 g cm^{-3}

462. 9702_s19_qp_12 Q: 15

A volume of 1.5 m^3 of water is mixed with 0.50 m^3 of alcohol. The density of water is 1000 kg m^{-3} and the density of alcohol is 800 kg m^{-3} .

The volume of the mixture is 2.0 m^3 .

What is the density of the mixture?

- A 850 kg m^{-3} B 900 kg m^{-3} C 940 kg m^{-3} D 950 kg m^{-3}

463. 9702_s19_qp_12 Q: 21

The diagram shows the arrangement of atoms in a particular crystal.

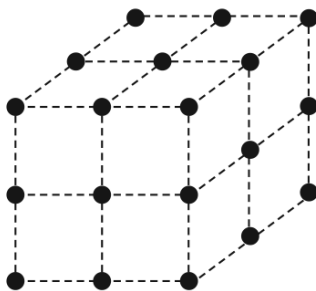

Each atom is at the corner of a cube.

The mass of each atom is 3.5×10^{-25} kg. The density of the crystal is 9.2×10^3 kg m⁻³.

What is the shortest distance between the centres of two adjacent atoms?

- A 3.8×10^{-29} m
- B 6.2×10^{-15} m
- C 3.4×10^{-10} m
- D 3.0×10^{-9} m

464. 9702_s19_qp_13 Q: 14

Water has a density of 1.0 g cm^{-3} .

Glycerine has a density of 1.3 g cm^{-3} .

A student measures out a volume of 40 cm^3 of glycerine into a container.

The student adds water to the container to make a mixture of water and glycerine. Assume that the total volume of water and glycerine does not change when the two liquids are mixed.

Which volume of water needs to be added to make a mixture of density 1.1 g cm^{-3} ?

- A 4.0 cm^3
- B 8.0 cm^3
- C 34 cm^3
- D 80 cm^3

465. 9702_w19_qp_11 Q: 11

An object of weight W is suspended from a newton meter. When the object is completely immersed in water, the newton meter reads P . When the object is completely immersed in oil, the newton meter reads Q .

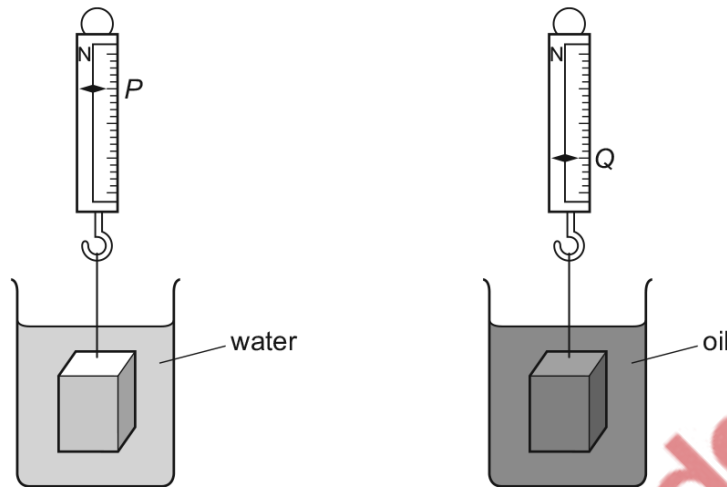

What is the ratio $\frac{\text{density of oil}}{\text{density of water}}$?

- A $\frac{W-P}{Q-P}$ B $\frac{Q-P}{W-P}$ C $\frac{W-P}{W-Q}$ D $\frac{W-Q}{W-P}$

466. 9702_w19_qp_11 Q: 14

In a large container in an oil refinery, three oils of different densities are mixed. No chemical activity occurs.

The mixture consists of:

1200 kg of oil of density 1100 kg m^{-3}

1500 kg of oil of density 860 kg m^{-3}

4000 kg of oil of density 910 kg m^{-3} .

What is the density of the mixture?

- A 927 kg m^{-3} B 933 kg m^{-3} C 957 kg m^{-3} D 1045 kg m^{-3}

467. 9702_w19_qp_12 Q: 13

Four measuring cylinders are filled with the same liquid to the heights shown.

At which position is the pressure the greatest?

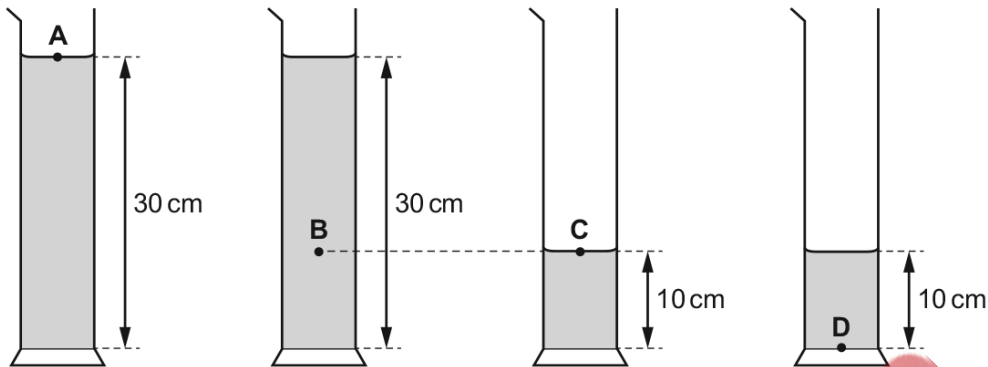

468. 9702_w19_qp_13 Q: 10

A solid sphere, which is less dense than water, is held completely immersed in water a few metres below the surface. The density of the water is uniform.

The sphere is released. Immediately after release, the sphere rises.

Which row correctly describes the changes in the upthrust on the sphere and the resultant force on the sphere?

	upthrust on the sphere	resultant force on the sphere
A	constant	increasing
B	constant	decreasing
C	decreasing	increasing
D	decreasing	decreasing

469. 9702_w19_qp_13 Q: 13

At sea level, atmospheric pressure is 100 kPa and the density of air is 1.3 kg m^{-3} .

Assume that the density of air decreases linearly with height above sea level.

What is an estimate of the total height of the atmosphere based on this information?

- A** 7.8 km **B** 16 km **C** 77 km **D** 150 km

470. 9702_m18_qp_12 Q: 4

The density of paper is 800 kg m^{-3} . A typical sheet of paper has a width of 210 mm and a length of 300 mm.

The thickness of a pack of 500 sheets of paper is 50 mm.

What is the mass of a single sheet of paper?

- A** 0.5g **B** 5g **C** 50g **D** 500g

471. 9702_s18_qp_11 Q: 11

Blocks P, Q, R and S are made from material of the same density. Block T is made from a material of twice the density of the material of the other blocks.

The cross-sectional area and height of each of the blocks are shown.

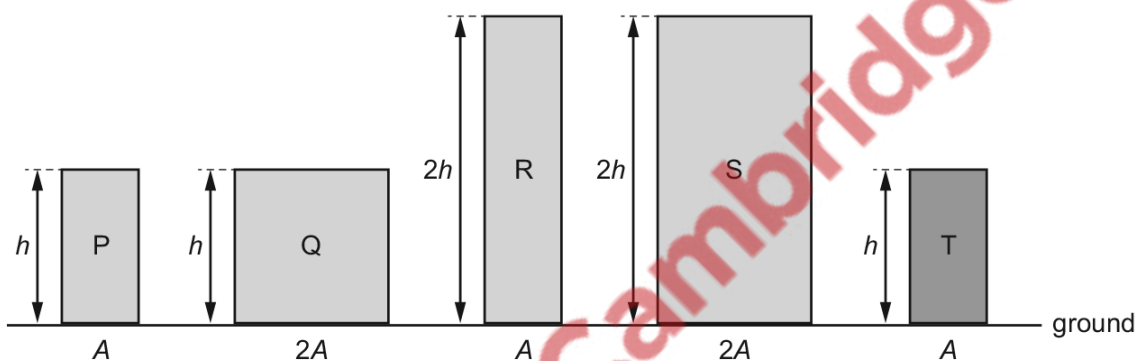

Which two blocks exert the same pressure on the ground?

- A** P and T **B** Q and R **C** Q and S **D** S and T

472. 9702_s18_qp_11 Q: 13

Liquids X and Y are stored in large open tanks. Liquid X has a density of 800 kg m^{-3} and liquid Y has a density of 1200 kg m^{-3} .

At which depths are the pressures equal?

	depth in liquid X/m	depth in liquid Y/m
A	8	20
B	10	15
C	15	10
D	20	8

473. 9702_s18_qp_12 Q: 10

The density of water is 1.0 g cm^{-3} and the density of glycerine is 1.3 g cm^{-3} .

Water is added to a measuring cylinder containing 40 cm^3 of glycerine so that the density of the mixture is 1.1 g cm^{-3} . Assume that the mixing process does not change the total volume of the liquid.

What is the volume of water added?

- A** 40 cm^3 **B** 44 cm^3 **C** 52 cm^3 **D** 80 cm^3
-

474. 9702_s18_qp_12 Q: 12

A cylindrical block of wood has cross-sectional area A and weight W . It is totally immersed in water with its axis vertical. The block experiences pressures p_t and p_b at its top and bottom surfaces respectively.

Which expression is equal to the upthrust on the block?

- A** $(p_b - p_t)$
B $(p_b - p_t)A$
C $(p_b - p_t)A - W$
D $(p_b - p_t)A + W$
-

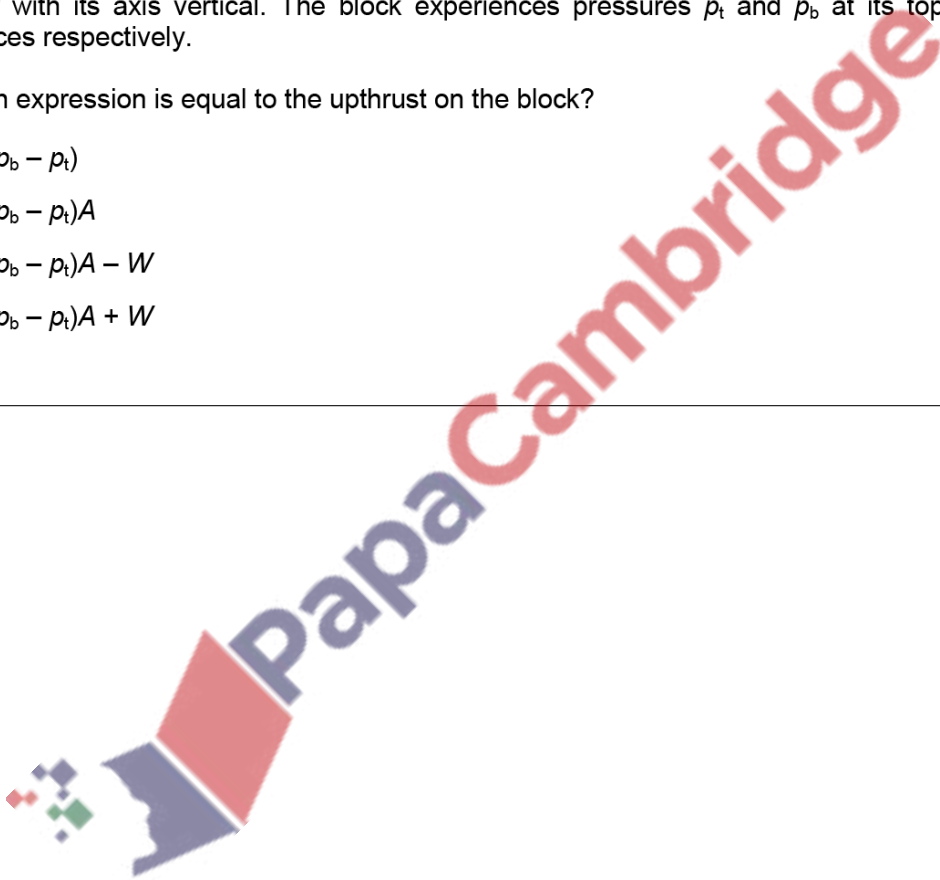

475. 9702_s18_qp_13 Q: 10

Four cuboids with identical lengths, breadths and heights are immersed in water. The cuboids are held at the same depth and in identical orientations by vertical rods, as shown.

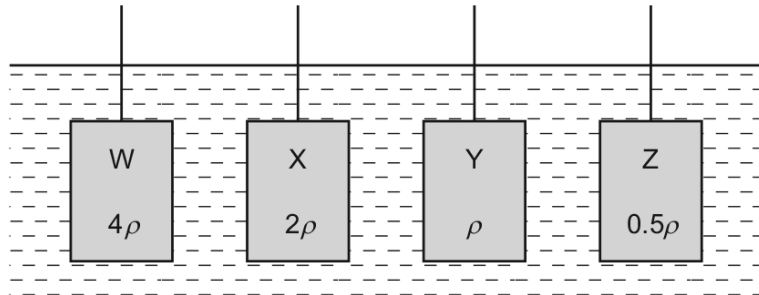

Water has density ρ .

Cuboid W is made of material of density 4ρ .

Cuboid X is made of material of density 2ρ .

Cuboid Y is made of material of density ρ .

Cuboid Z is made of material of density 0.5ρ .

Which statement is correct?

- A The upthrust of the water on each of the cuboids is the same.
- B The upthrust of the water on W is twice the upthrust of the water on X.
- C The upthrust of the water on X is twice the upthrust of the water on W.
- D The upthrust of the water on Y is zero.

476. 9702_s18_qp_13 Q: 11

A rectangular block of lead of density $1.13 \times 10^4 \text{ kg m}^{-3}$ has sides of length 12.0 cm, 15.0 cm and 10.0 cm.

What is the maximum pressure the block can exert when resting on a table?

- A 1.13 kPa
- B 1.70 kPa
- C 11.1 kPa
- D 16.6 kPa

477. 9702_s18_qp_13 Q: 13

Full-fat milk is made up of fat-free milk mixed with fat.

A volume of $1.000 \times 10^{-3} \text{ m}^3$ of full-fat milk has a mass of 1.035 kg. It contains 4.00% fat by volume.

The density of fat-free milk is $1.040 \times 10^3 \text{ kg m}^{-3}$.

What is the density of fat?

- A $1.25 \times 10^2 \text{ kg m}^{-3}$
- B $9.15 \times 10^2 \text{ kg m}^{-3}$
- C $9.28 \times 10^2 \text{ kg m}^{-3}$
- D $1.16 \times 10^3 \text{ kg m}^{-3}$

478. 9702_w18_qp_11 Q: 13

A vertical tube, closed at one end, is immersed in water. A column of air is trapped inside the tube.

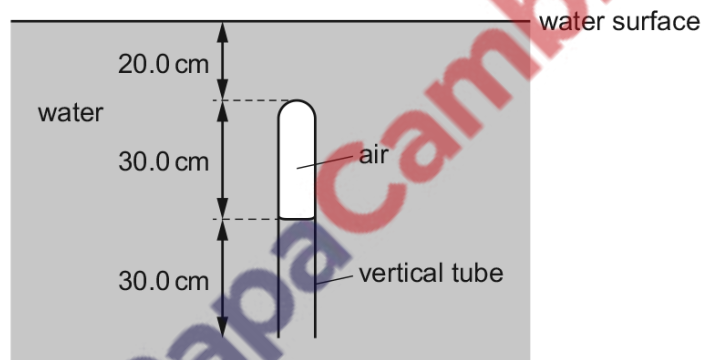

The density of water is 1000 kg m^{-3} .

What is the difference between the pressure of the air in the tube and the atmospheric pressure?

- A 1960 Pa
- B 2940 Pa
- C 4910 Pa
- D 7850 Pa

479. 9702_w18_qp_12 Q: 14

The density of the air in the atmosphere decreases as the height h above the surface of the Earth increases.

Which graph best shows the variation with height h of the pressure p of the air?

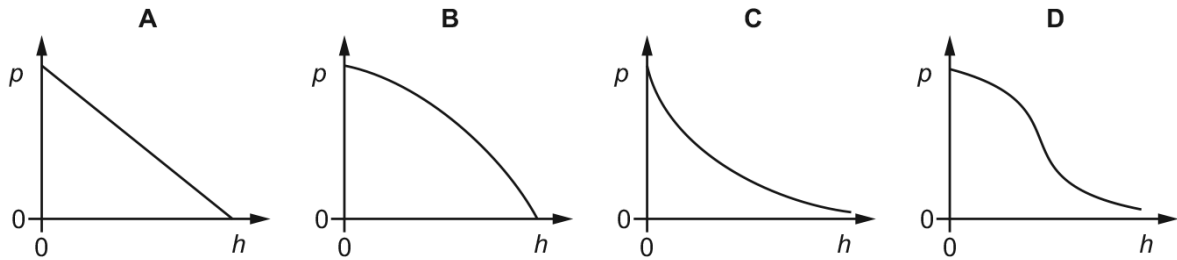

480. 9702_w18_qp_13 Q: 14

What is a unit for density?

- A Nm^{-3} B gmm^{-1} C kgcm^{-2} D μgmm^{-3}

481. 9702_s17_qp_11 Q: 14

A metal block has a mass of 750 g. 60% of the mass is magnesium and the remainder is copper.

The density of magnesium is 1.7 g cm^{-3} .

The density of copper is 9.0 g cm^{-3} .

What is the density of the block?

- A 2.5 g cm^{-3} B 4.6 g cm^{-3} C 5.4 g cm^{-3} D 10.7 g cm^{-3}

482. 9702_s17_qp_12 Q: 13

What are the SI base units of the quantity $\frac{\text{pressure}}{\text{density}}$?

- A s^{-2} B $\text{kg}^2 \text{s}^{-2}$ C $\text{kg}^2 \text{m}^2 \text{s}^{-2}$ D $\text{m}^2 \text{s}^{-2}$

483. 9702_w17_qp_12 Q: 15

Air is trapped inside a glass bulb which is immersed in water and attached to a U-tube containing mercury. The densities of water and mercury are ρ_w and ρ_m respectively. The surface of the water is open to the atmosphere where atmospheric pressure is P .

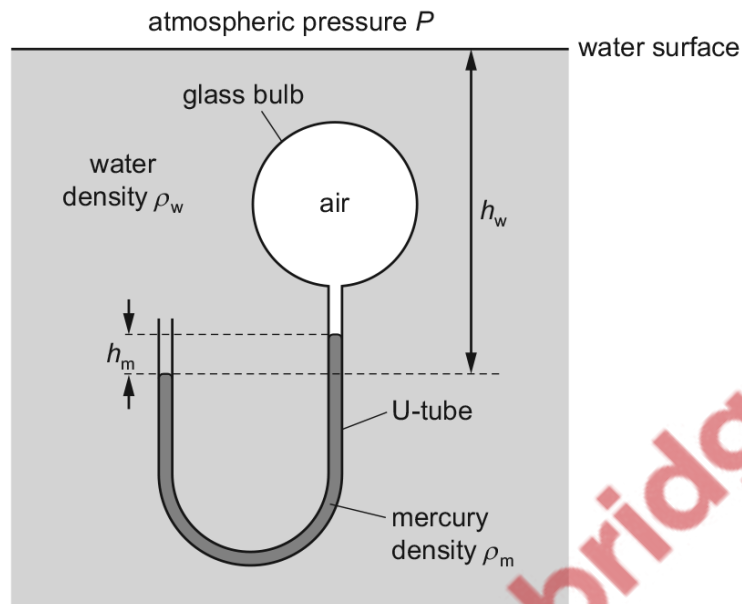

The acceleration of free fall is g .

What is the pressure of the air in the glass bulb?

- A $P + g\rho_w h_w + g\rho_m h_m$
- B $P + g\rho_w h_w - g\rho_m h_m$
- C $g\rho_w h_w + g\rho_m h_m$
- D $g\rho_w h_w - g\rho_m h_m$

484. 9702_w17_qp_13 Q: 14

A thin horizontal plate of area 0.036 m^2 is beneath the surface of a liquid of density 930 kg m^{-3} . The force on one side of the plate due to the pressure of the liquid is 290 N .

What is the depth of the plate beneath the surface of the liquid?

- A 0.88 m
- B 1.1 m
- C 1.8 m
- D 8.7 m

485. 9702_m16_qp_12 Q: 14

A giant squid of length 20.0 m is vertical in seawater, with the top of the squid at a depth of 8.00 m. The density of seawater is 1050 kg m^{-3} .

What is the difference in pressure between the top and the bottom of the squid?

- A** 82 000 Pa **B** 206 000 Pa **C** 288 000 Pa **D** 389 000 Pa

486. 9702_s16_qp_11 Q: 13

A solid metal cylinder stands on a horizontal surface, as shown.

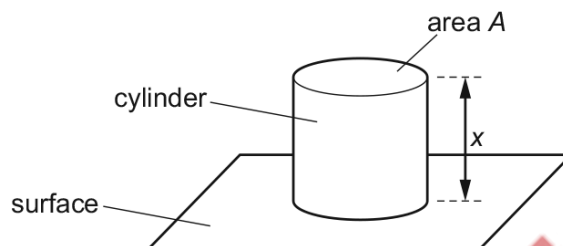

The cylinder has length x and cross-sectional area A . The cylinder exerts a pressure p on the surface. The acceleration of free fall is g .

Which expression gives the density of the metal of the cylinder?

- A** $\frac{gx}{p}$ **B** $\frac{p}{gx}$ **C** $\frac{gx}{pA}$ **D** $\frac{pA}{gx}$

487. 9702_s16_qp_11 Q: 15

The diameter of a solid metal sphere is measured using a micrometer screw gauge. The diagram shows an enlargement of the shaft of the micrometer screw gauge when taking the measurement.

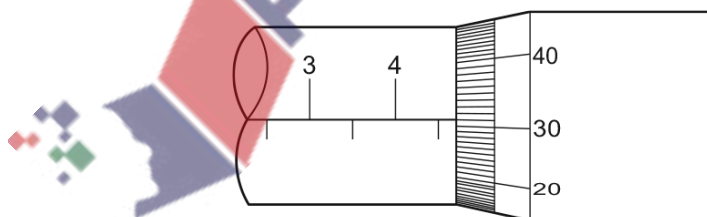

The mass of the sphere is 0.450 g.

What is the density of the metal used to make the sphere?

- A** 965 kg m^{-3} **B** 1340 kg m^{-3} **C** 7720 kg m^{-3} **D** 10700 kg m^{-3}

488. 9702_s16_qp_12 Q: 13

In a large container in an oil refinery, three oils of different densities are mixed. No chemical activity occurs.

The mixture consists of

1200 kg of oil of density 1100 kg m^{-3} ,

1500 kg of oil of density 860 kg m^{-3} ,

4000 kg of oil of density 910 kg m^{-3} .

What is the density of the mixture?

- A** 927 kg m^{-3} **B** 957 kg m^{-3} **C** 1010 kg m^{-3} **D** 1080 kg m^{-3}
-

489. 9702_s16_qp_12 Q: 15

The density of air on the Earth decreases almost linearly with height from 1.22 kg m^{-3} at sea level to 0.74 kg m^{-3} at an altitude of 5000 m.

Atmospheric pressure at the Earth's surface on a particular day is 100 000 Pa. The value of g between the Earth's surface and an altitude of 5000 m can be considered to have a constant value of 9.7 m s^{-2} .

What will be the atmospheric pressure at an altitude of 5000 m?

- A** 36 000 Pa **B** 48 000 Pa **C** 52 000 Pa **D** 59 000 Pa
-

490. 9702_s16_qp_13 Q: 11

The IKAROS satellite has mass 320 kg and moves through space using a solar sail of area 20 m^2 . The average solar wind pressure is $1.0 \times 10^{-5} \text{ N m}^{-2}$.

What is the acceleration of the satellite caused by the solar wind?

A $3.1 \times 10^{-8} \text{ m s}^{-2}$

B $6.3 \times 10^{-7} \text{ m s}^{-2}$

C $3.2 \times 10^{-3} \text{ m s}^{-2}$

D $6.4 \times 10^{-2} \text{ m s}^{-2}$

491. 9702_s16_qp_13 Q: 15

For a change in depth Δh in a liquid of density ρ , the change in pressure Δp is given by $\Delta p = \Delta h \rho g$ where g is the acceleration of free fall.

What is the equation, or principle of physics, used in the derivation of this formula?

- A atmospheric pressure decreases with height
- B change in gravitational potential energy = mass \times $g\Delta h$
- C $\rho = \frac{\text{mass}}{\text{volume}}$
- D the density of a fluid increases with depth

492. 9702_w16_qp_11 Q: 14

A submarine has circular windows of diameter 0.30 m. The windows can experience a maximum external pressure of 660 kPa before they crack.

What is the minimum external force needed to crack the windows?

- A 47 000 N
- B 190 000 N
- C 310 000 N
- D 620 000 N

493. 9702_w16_qp_13 Q: 14

A submarine has circular windows of diameter 0.30 m. The windows can experience a maximum external pressure of 660 kPa before they crack.

What is the minimum external force needed to crack the windows?

- A 47 000 N
- B 190 000 N
- C 310 000 N
- D 620 000 N

494. 9702_s15_qp_12 Q: 20

The maximum pressure that granite rock can withstand is $2.0 \times 10^8 \text{ N m}^{-2}$. Above this pressure, the rock begins to flow like a liquid. The density of granite is $2.7 \times 10^3 \text{ kg m}^{-3}$.

What would be the height of a pure granite mountain whose base is just beginning to flow?

- A $3.8 \times 10^3 \text{ m}$
- B $7.6 \times 10^3 \text{ m}$
- C $3.7 \times 10^4 \text{ m}$
- D $7.4 \times 10^4 \text{ m}$

495. 9702_s15_qp_13 Q: 14

Four cuboids with identical length, breadth and height are immersed in water. The cuboids are held at the same depth and in identical orientations by vertical rods, as shown.

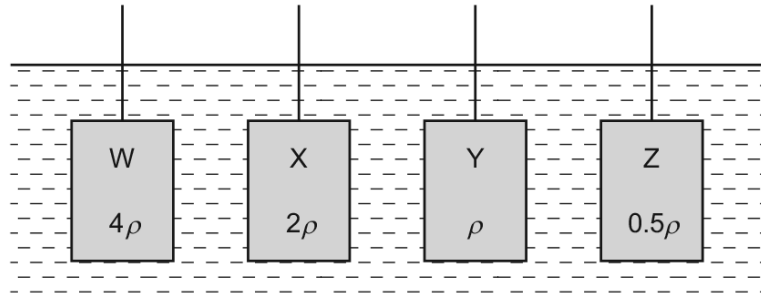

Water has density ρ .

Cuboid W is made of material of density 4ρ .

Cuboid X is made of material of density 2ρ .

Cuboid Y is made of material of density ρ .

Cuboid Z is made of material of density 0.5ρ .

Which statement is correct?

- A The upthrust of the water on each of the cuboids is the same.
- B The upthrust of the water on W is twice the upthrust of the water on X.
- C The upthrust of the water on X is twice the upthrust of the water on W.
- D The upthrust of the water on Y is zero.



496. 9702_s15_qp_13 Q: 15

An air bubble in a tank of water is rising with constant velocity. The forces acting on the bubble are X, Y and Z as shown.

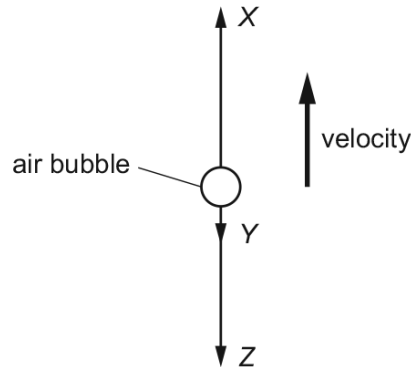

What describes the three forces?

- A** Z is the viscous drag on the bubble, Y is the weight of the bubble, X is the upthrust on the bubble and $X = Y + Z$.
- B** Z is the viscous drag on the bubble, Y is the weight of the bubble, X is the upthrust on the bubble and $X > Y + Z$.
- C** Z is the weight of the bubble, Y is the viscous drag on the bubble, X is the upthrust on the bubble and $X = Y + Z$.
- D** Z is the weight of the bubble, Y is the viscous drag on the bubble, X is the upthrust on the bubble and $X > Y + Z$.

497. 9702_s15_qp_13 Q: 20

When ice melts, it contracts.

Which row is correct for ice turning into water?

	distance between molecules	density
A	decreases	decreases
B	decreases	increases
C	increases	decreases
D	increases	increases

498. 9702_s15_qp_13 Q: 21

A W-shaped tube contains two amounts of mercury, each open to the atmosphere. Air at pressure P is trapped in between them. The diagram shows two vertical distances x and y .

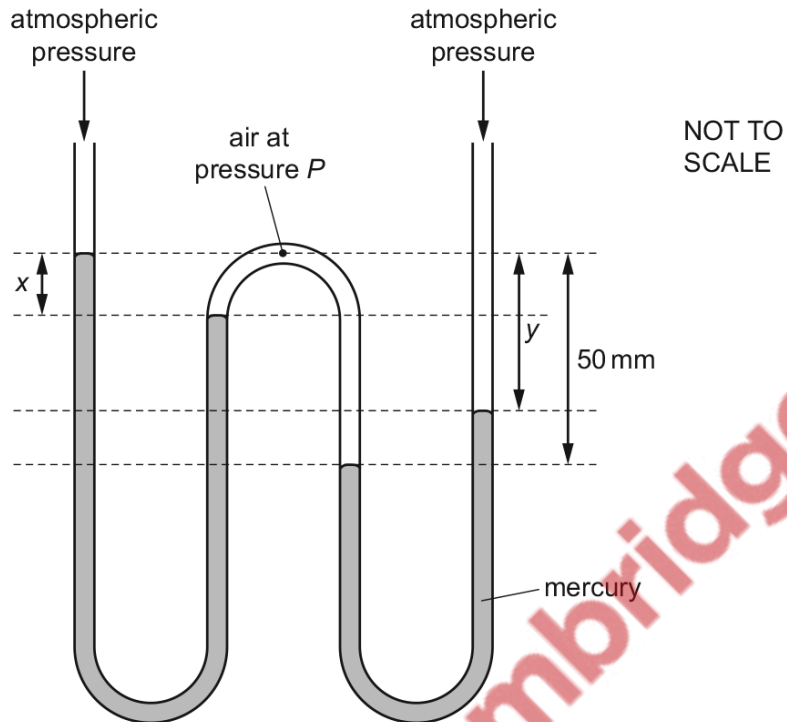

Atmospheric pressure is equal to the pressure that would be exerted by a column of mercury of height 760 mm. The pressure P is expressed in this way.

Which values of x , y and P are possible?

	x/mm	y/mm	$P/\text{mm of mercury}$
A	20	20	780
B	20	30	780
C	30	20	810
D	30	30	790